

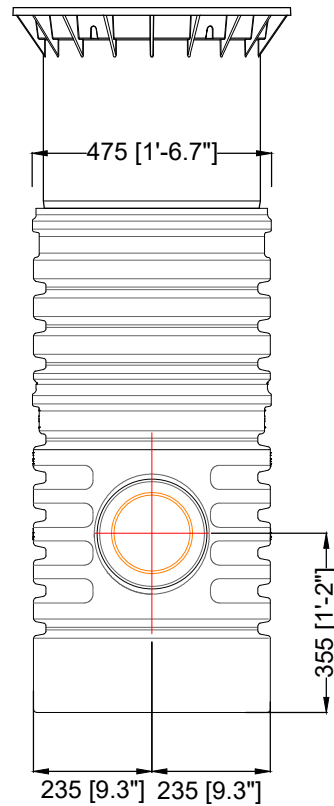

Achtung: Die Länge des Überlaufrohres muss an die Tankhöhe angepasst werden!

Attention: The length of the overflow pipe has to be adjusted to the tank height!

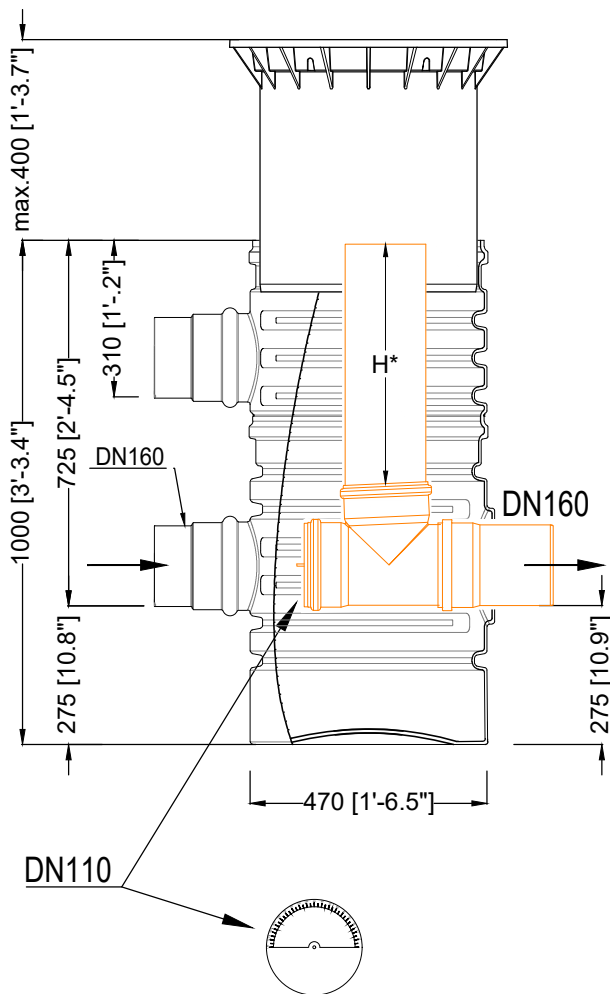
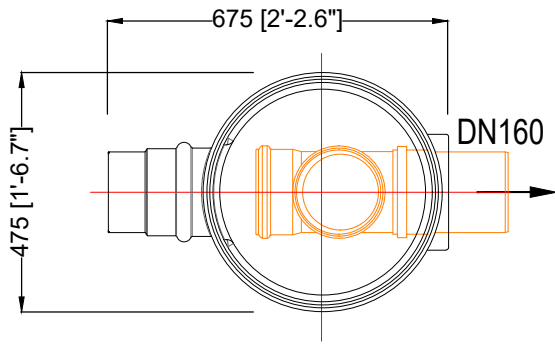

<b>D</b> <b>GRAF Drosselablaufschaft</b> <b>begehbar / PKW-befahrbar / LKW-befahrbar</b>		Artikel-Nr. product no. 340028 article no. 340029 / 340019 articulo no.
<b>GB</b> Choke drain shaft suitable for pedestrian/ vehicle loading/ D400 lorry-bearing	<b>ES</b> Pozos de estrangulación por peatrones/ por coches/ D400 transitable por camiones	<b>FR</b> Regard Débit Régulé piétons/ véhicules/ D400 passage véhicules camion
gezeichnet drawn <b>ISC</b>	Gewicht weight <b>24/ 55/ 75 kg</b>	<b>Otto Graf GmbH</b> Carl-Zeiss-Str. 2-6 DE-79331 Teningen mail@graf.info www.graf.info
Datum date <b>2023.11.20</b>	Toleranz tolerance <b>+/- 3%</b>	
Maßstab scale <b>M 1:15</b>	Einheiten units <b>mm [inch]</b> <b>gal. = US gal.</b>	

