



Installation manual

Carat S Tank



1. GENERAL NOTES

The points described in these instructions must be followed correctly. If not correctly observed, any right to claim on the warranty may be refused.

Any missing instructions must be requested directly from us.

A complete check of all the items/components for possible damage must be carried out before the assembly or installation begins.

The installation must be carried out in a professional manner.

Safety

The relevant accident prevention regulations must be observed during all work.

The relevant regulations and standards must additionally be taken into consideration during installation, assembly, servicing, repair, etc.

The system or individual parts of the system must be installed by qualified specialists.

During all work on the system or parts of the system, the entire system must always be rendered inoperable and secured to prevent unauthorised reactivation.

Except in the event of work carried out in the tank, the cover of the tank must always be kept sealed, as this otherwise constitutes a maximum risk of accident. Only original GRAF covers or covers approved in writing by GRAF must be used.

GRAF offers an extensive range of accessories, all of which are designed to match each other and which can be extended to form complete systems. The use of accessories that have not been approved by GRAF results in the exclusion of the warranty/guarantee.

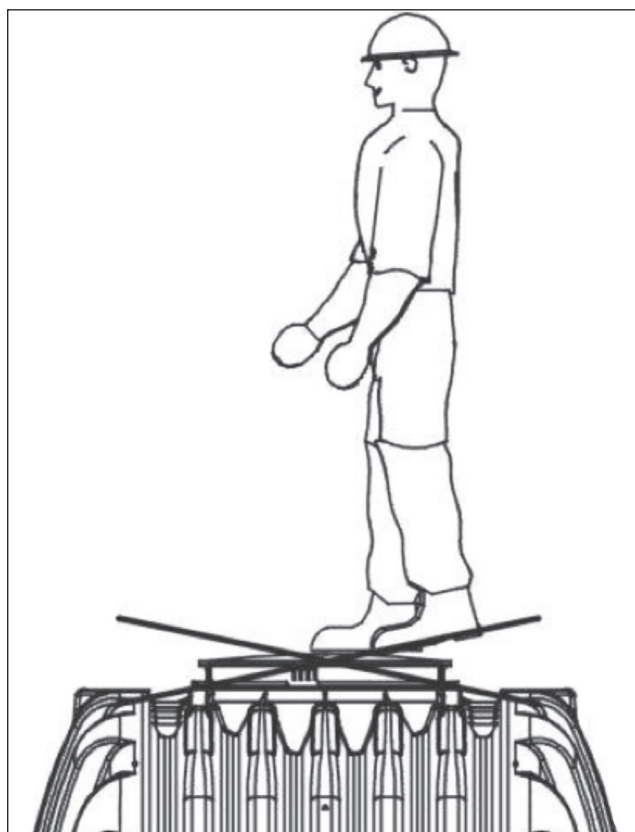

Identification obligation - Regulation

The water in these systems is not suitable for consumption or personal hygiene.

All pipe-work and outlets of the water systems are to be labelled with the words "Not drinking water" either in words or graphically. (British Standard BS EN 16941-1:2024) so that after years of use, an accidental connection to the drinking water system is prevented. Even when correctly labelled it may possibly be mistaken, for example by children. For this reason, all the outlets of the systems process water must be fitted with child safe valves.

2. TECHNICAL DATA

2.1 Technical Data Carat

* Telescopic dome shaft at maximum height

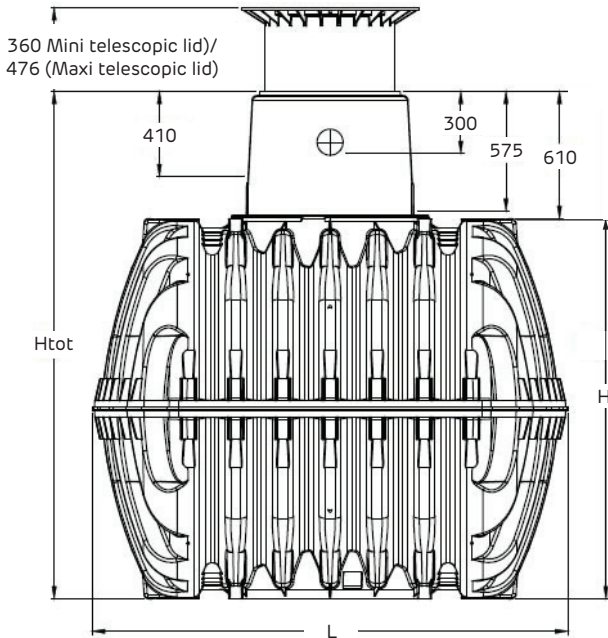

* Telescopic dome shaft at minimum height

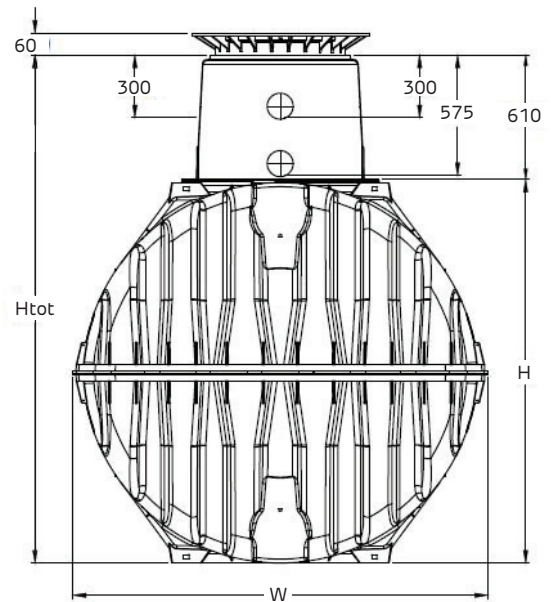

2.2 Overview Tanks - Carat

Tank	2700 litres	3750 litres	4800 litres	6500 litres
Weight	120 kg	150 kg	185 kg	220 kg
L	2080 mm	2280 mm	2280 mm	2390 mm
W	1565 mm	1755 mm	1985 mm	2190 mm
H	1400 mm	1590 mm	1820 mm	2100 mm
Htot*	2010 mm	2200 mm	2430 mm	2710 mm

* Htot = total height (without telescopic dome shaft)

3. TANK STRUCTURE

1. Cover
2. Telescopic dome shaft (can be inclined by 5°)
3. Profile seal
4. Tank dome (can be rotated by 360°)
5. Tank – Tank dome seal
6. Upper half shell / Carat underground tank
7. Centring pins
8. Profile seal
9. Quick connection
10. Lower half shell / Carat underground tank

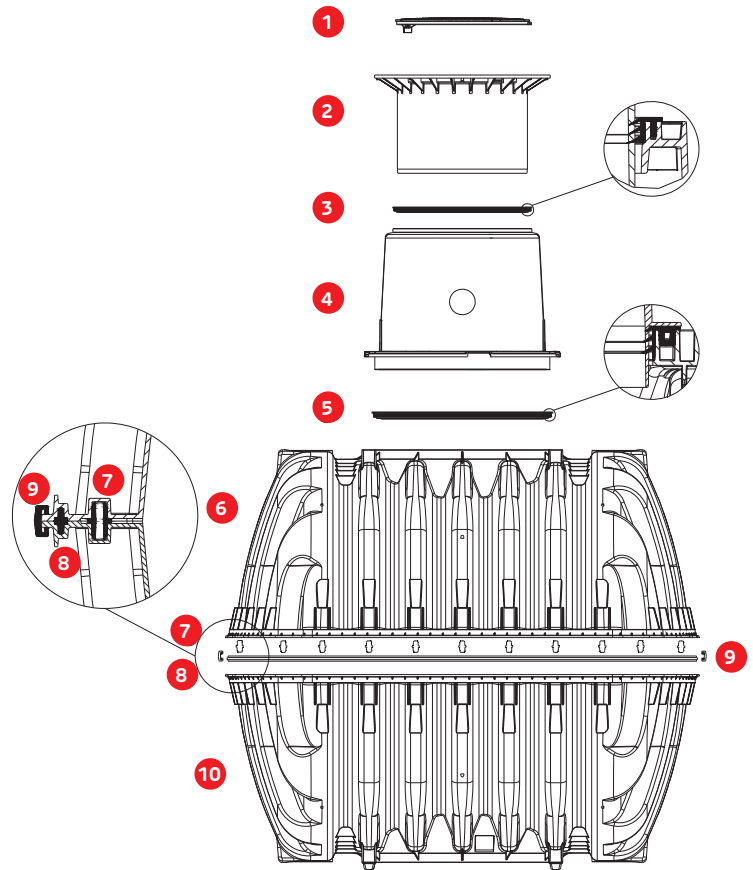

3.1 Tank assembly

First insert the circumferential profile seal **2** into the sealing groove in the lower half shell **1**. Lightly coat the seal with the enclosed soft soap.

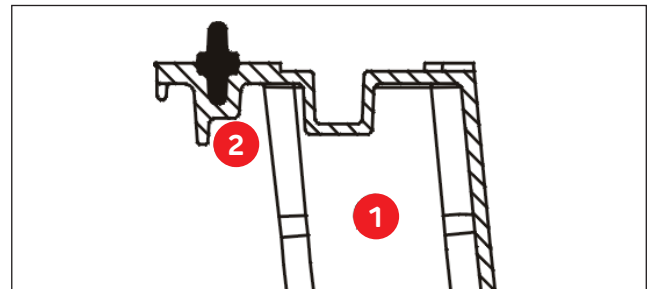

Then insert the centring pins **3** into the intended mountings around the circumference.

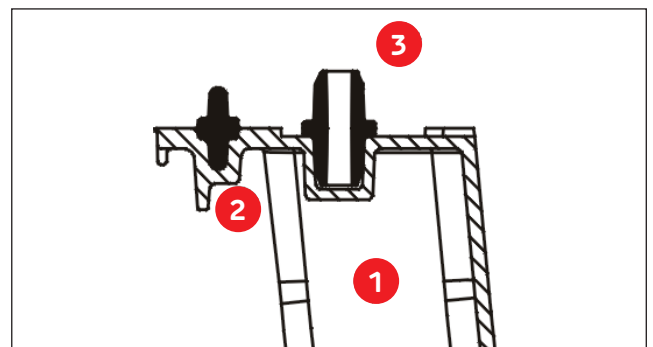

The upper half shell **4** is now positioned onto the lower half shell **1** and the quick connectors **5** are installed. To do this, each 2nd quick connector is pre-adjusted in the 1st step and is secured with a hammer and a wooden support. The quick connectors engage in their end position. The remaining quick connectors are then installed.

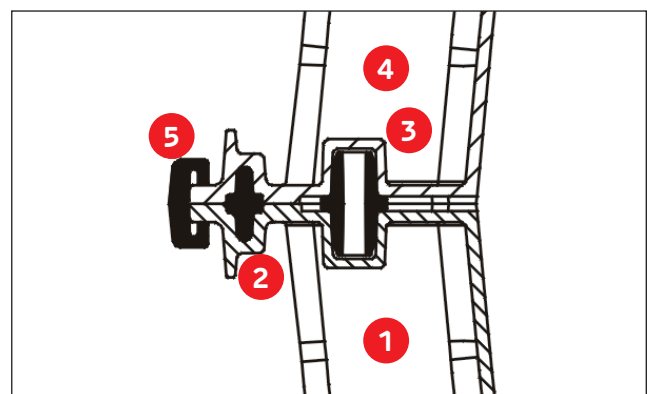

Attention: When positioning the upper half shell, it must be ensured, under all circumstances, that the seal does not slip out of the groove.

4. INSTALLATION AND ASSEMBLY

4. Installation conditions

- | | |
|--|---|
| 1. Subsoil | 5. Covering layer |
| 2. Telescopic dome shaft | 6. Carat underground tank |
| 3. Compact foundation | 7. Concrete layer for surfaces used by passenger cars |
| 4. Surrounding (round-grained gravel, maximum grain size 10 to 20mm) | |

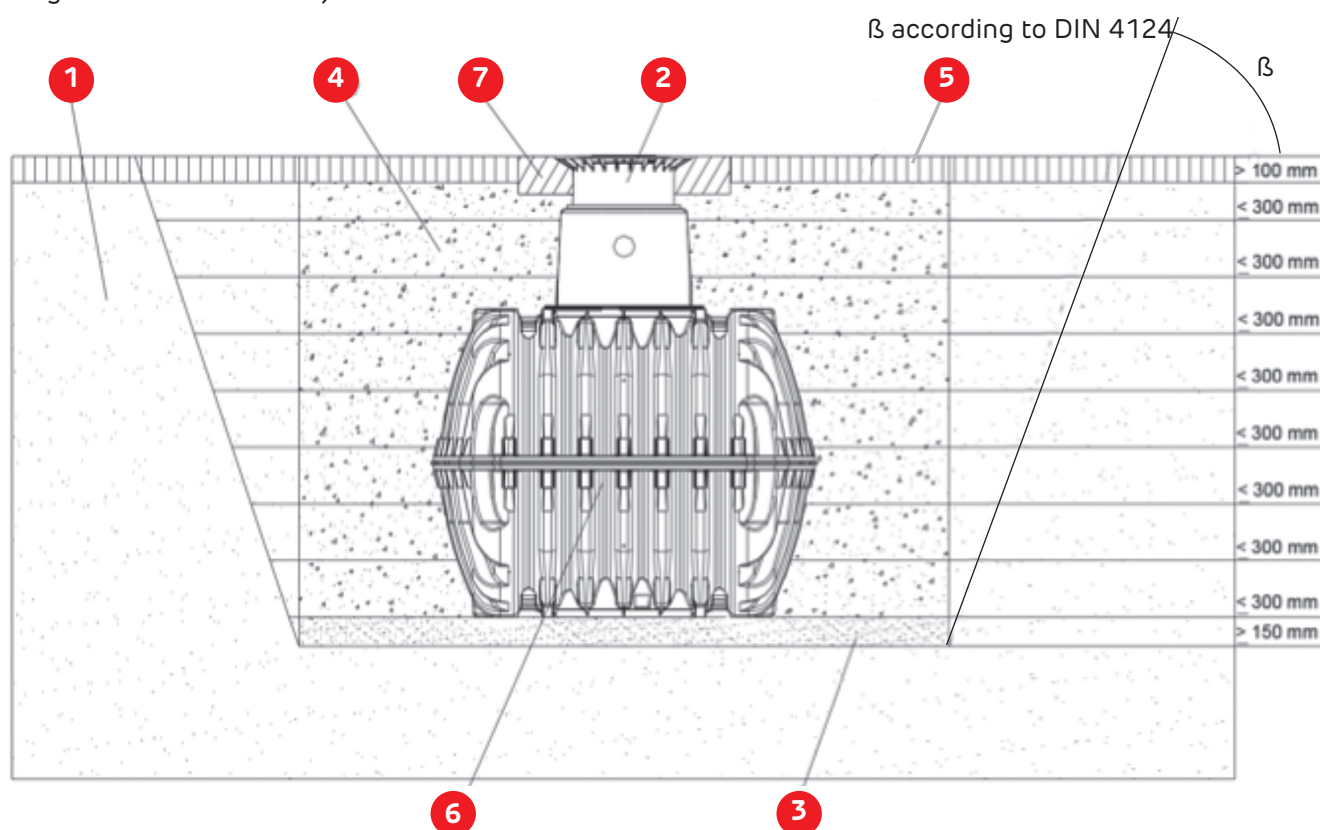

4.1 Construction site

Under all circumstances, the following points must be clarified prior to installation:

- The structural suitability of the ground according to DIN 18196
- Maximum groundwater levels which occur and drainage capability of the subsoil
- Types of load which occur, e.g. traffic loads

An expert ground report should be requested from the local planning authority to determine the physical characteristics of the subsoil.

4.2 Trench

To ensure that sufficient space is available for working, the base area of the trench must exceed the dimensions of the tank by 500 mm on each side; the distance from solid structures must be at least 1000 mm.

The trench embankment must be designed so that slippage or collapse of the embankment wall is not to be anticipated. The construction site must be horizontal and plane and must guarantee sufficient load-bearing capacity.

The depth of the trench must be dimensioned so that the max. earth coverage (see installation conditions) above the tank is not exceeded. To use the system throughout the entire year, it is necessary to install the tank and those parts of the system which hold water in a frost-free area. The frost-free depth is usually approx. 600 mm – 800 mm; precise information in this regard can be obtained from the responsible authority.

A layer of compacted, round-grain gravel (grain size 10/20, thickness approx. 150 - 200 mm) is applied as the foundation.

4. INSTALLATION AND ASSEMBLY

4.3 Standard installation overview

Coverage heights with telescopic dome shaft in green areas.

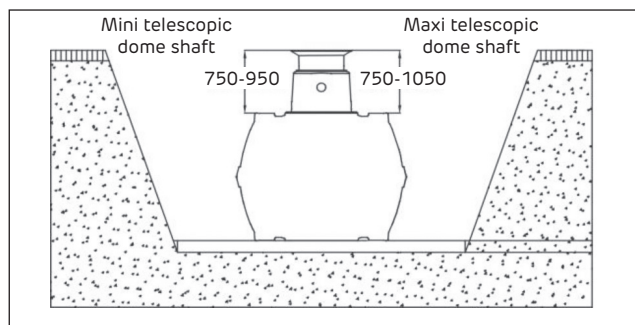

4.4 Maximum cover permitted over tank

Maximum coverage heights with extensions and telescopic dome shaft.

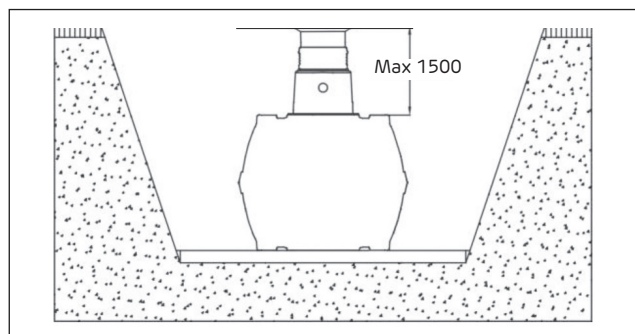

4.5 Slope, embankment, etc.

On installation of the tank in the immediate vicinity (<5 m) of a slope, earthen mound or slope, a statically calculated supporting wall must be erected to absorb the soil pressure. The wall must exceed the dimensions of the tank by at least 500 mm in all directions, and must be located at least 1000 mm away from the tank.

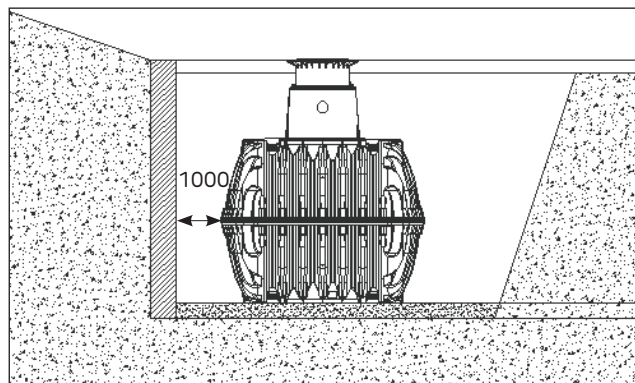

4.6 Groundwater and cohesive (water-impermeable) soils (e.g. clay soil)

If it is anticipated that the tanks will be immersed deeper into the groundwater than is shown in the adjacent figure, sufficient dissipation must be ensured. (See table for max. immersion depth).

Dissipation of the drainage water (e.g. via an annular drainage system) is recommended in the case of cohesive, water-impermeable soils.

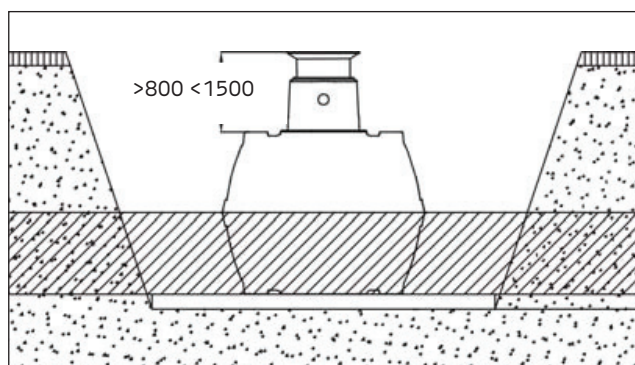

Tank	2700 litres	3750 litres	4800 litres	6500 litres
Immersion depth	700 mm	795 mm	910 mm	1050 mm

4. INSTALLATION AND ASSEMBLY

4.7 Installation below light-duty vehicle surfaces

Coverage heights with vehicle loading telescopic dome shaft (with class B vehicle loading cover) in areas with car traffic (load up to 3.5 t).

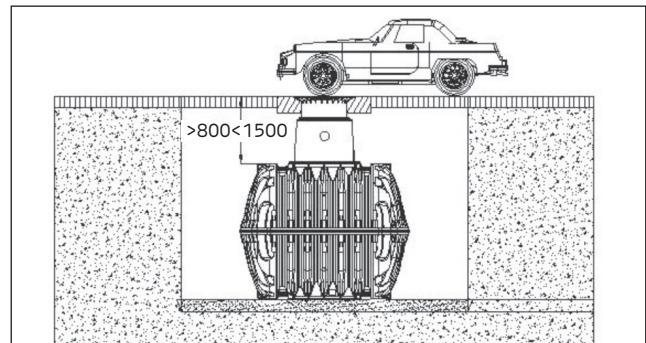

4.8 Installation below heavy-duty vehicle surfaces

Coverage heights (with cover class D – to be provided at construction site) in areas used by trucks with a max. weight of 12 t. Without groundwater or stratum water.

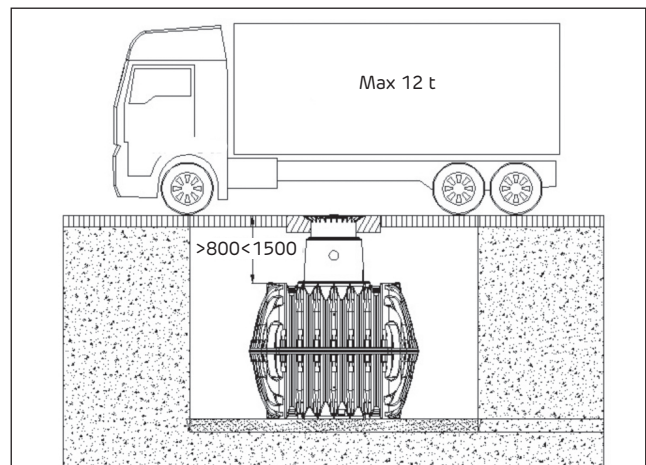

4.9 Installation adjacent to surfaces used by vehicles

If the underground tanks are installed adjacent to surfaces which are used by vehicles heavier than passenger cars, the minimum distance away from these surfaces is at least the depth of the trench.

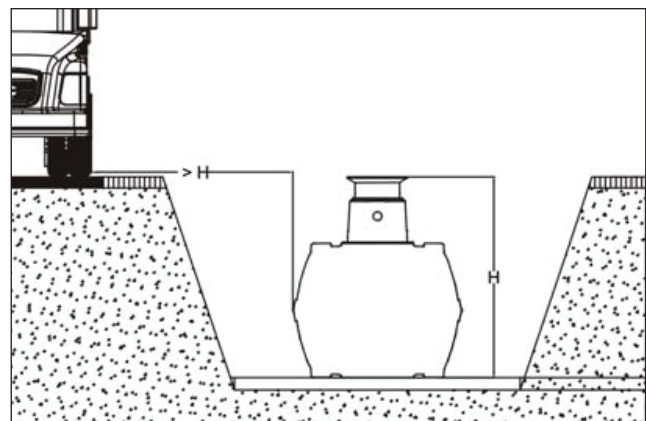

4. INSTALLATION AND ASSEMBLY

4.10 Connection of several tanks

Two or more tanks are connected via the assembly surfaces by means of GRAF special seals and basic pipes (to be provided at construction site).

The apertures must be drilled to the corresponding size using only the GRAF special crown bit. It must be ensured that the distance between the tanks is at least 600 mm. The pipes must project at least 200 mm into the tanks.

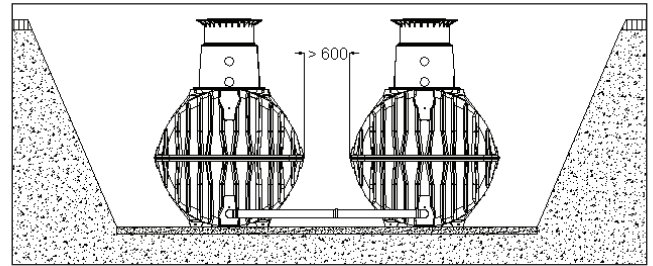

4.11 Insertion and filling

The tanks must be inserted, impact-free, into the prepared trench using suitable equipment. The tank is filled with 1/3 water before filling in the tank surrounding.

Afterwards the surrounding (roundgrain gravel, max. grain size 10-20mm) is then filled in layers of max. 30 cm steps and is compacted. The individual layers must be well-compacted (manual tamper). Damage to the tank must be avoided during compaction. Mechanical compaction machines must not be used under any circumstances. The surrounding must be at least 500 mm wide.

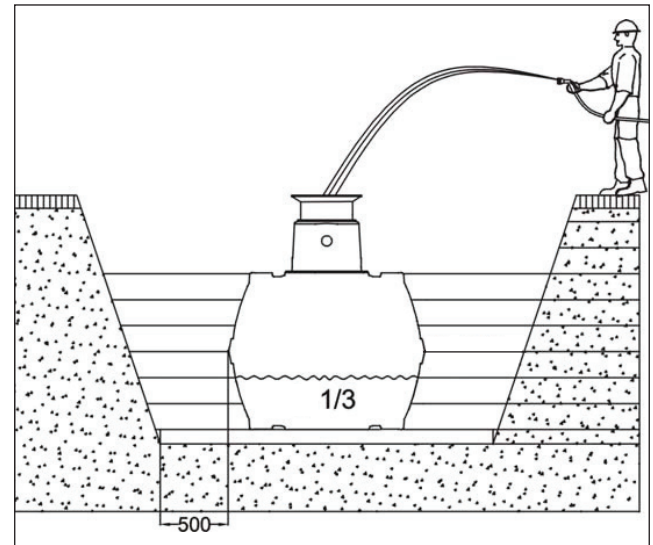

4.12 Routing connections

All feed and overflow pipes must be routed with a decline of at least 1% in the direction of flow (possible, subsequent settling must be taken into consideration in this case). If the tank overflow is connected to a public sewer, this must be protected against reflux by means of a lifting station (mixed sewer) or reflux seal (pure rainwater sewer) according to DIN 1986.

All suction, pressure and control lines must be routed in an empty pipe, which must be routed as straight as possible, without bending, to the tank with a decline. Necessary bends must be formed using 30° moulded sections.

Important: The empty pipe must be connected to an aperture above the max. water level.

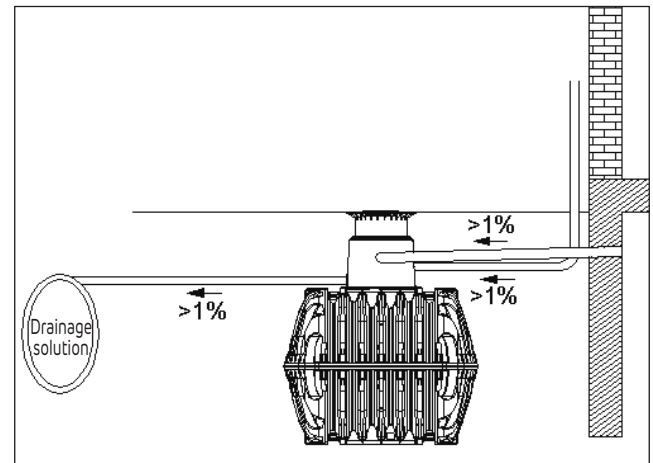

4.13 Routing connections - specific to Wastewater applications

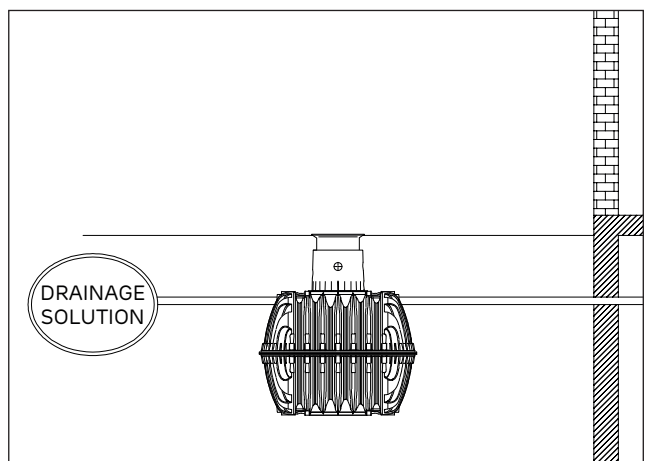

5. ASSEMBLING THE TANK DOME & TELESCOPIC DOME SHAFT

5.1 Assembling the tank dome

Prior to assembly, the enclosed seal is inserted into the tank domes' groove 'B'. The tank dome is then aligned with the piping connections and is locked to the tank neck. It is essential to make sure that the upper seal 'A' is correctly installed.

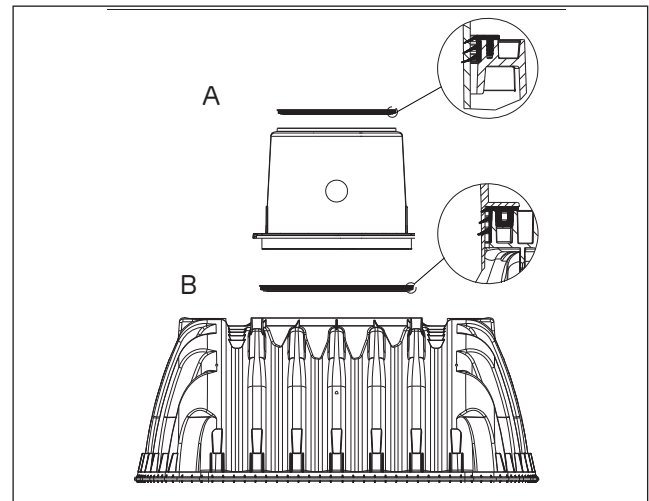
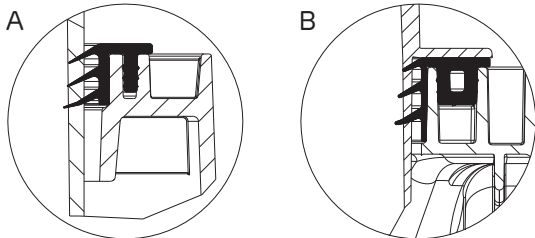

5.2 Assembling the telescopic dome shaft

The telescopic dome shaft enables infinite adaptation of the tank to given site surfaces with earth coverage of between 750 mm and 950 mm (Mini telescopic dome shaft) or 750 mm and 1050 mm (Maxi telescopic dome shaft).

For assembly purposes, the enclosed profile seal (material EPDM) is inserted into the tank dome's sealing groove and is coated generously with soft soap (do not use mineral oil-based lubricants, as these attack the seal). The telescopic dome shaft is then greased, inserted and aligned with the surface of the site.

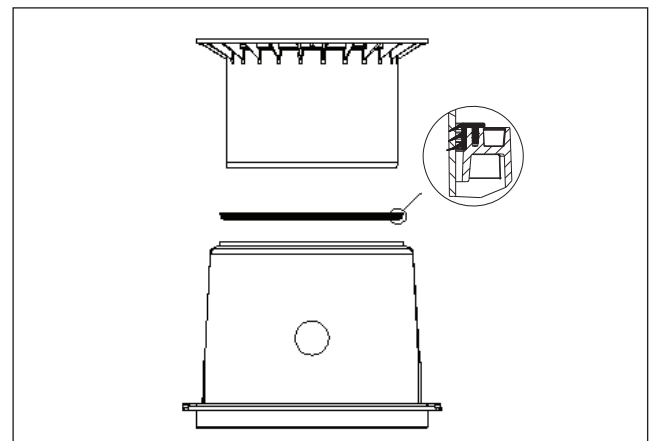

5.3 Telescopic dome shaft on which persons may walk

Important: To prevent loads from being transferred onto the tank, round-grain gravel **1** (max. grain size 10/20) is filled in layers around the telescopic dome shaft **2** and is evenly compacted. Damage to the tank dome **3** and telescopic dome shaft must be avoided during this step. The cover is then positioned and is sealed to prevent entry by children. Tighten the threaded connection on the cover so tightly that it cannot be opened by a child!

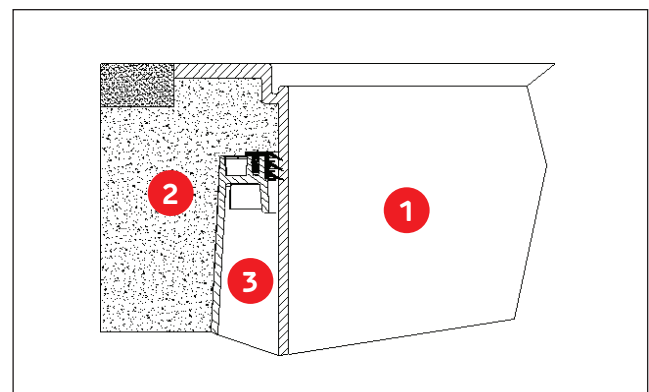

5.4 Telescopic dome shaft over which passenger cars may drive

If the tank is installed under areas used by passenger cars, the collar area of the telescopic dome shaft **1** (colour anthracite) must be supported with concrete **4** (load class B25 = 250 kg/m²). The layer of concrete to be installed must be at least 300 mm wide and approx. 200 mm high all around. The minimum coverage above the shoulder of the tank is at least 800 mm (max. 1050 mm with telescopic dome shaft and 1500 mm possible with extension).

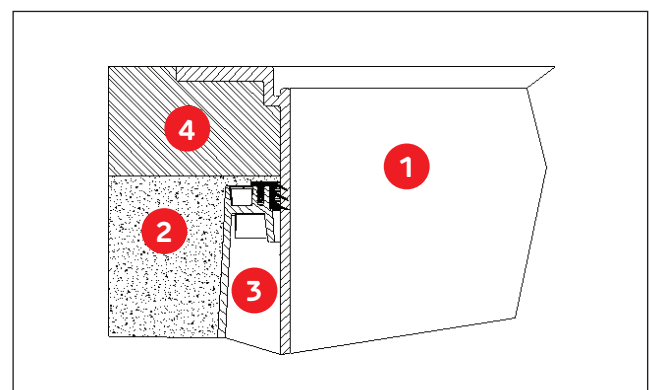

Attention: It is essential to use the vehicle loading telescopic dome shaft (with class B cast cover).

5. ASSEMBLING THE TANK DOME & TELESCOPIC DOME SHAFT

5.5 Assembling the extension

For larger coverage heights an extension is needed. To insert the extension into the tank dome, soft soap is needed. Into the highest groove of the extension the profile seal is inserted and greased generously. Afterwards push the telescopic dome shaft into the extension and adapt it to the planned area surface.

1 Extension = max. earth-cover 1500 mm (in each case in connection with the telescopic dome shaft)

- 1 Telescopic dome shaft (can be inclined by 5°)
- 2 Extension
- 3 Tank dome (can be rotated by 360°)

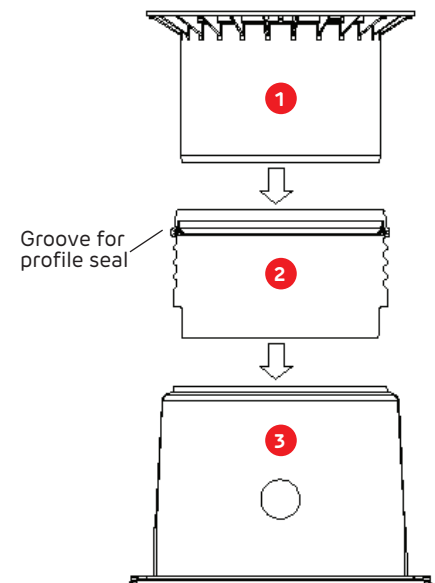

6. INSPECTION AND SERVICING

The entire system must be checked for leaks, cleanliness and stability at least every three months.

The entire system should be serviced at intervals of approx. 5 years. In this case, all parts of the system must be cleaned and their function checked. Servicing should be carried out as follows:

- Drain the tank completely
- Clean surfaces and internal parts with water
- Remove all dirt from the tank
- Check that all internal parts are firmly connected.

The points described in these instructions must be observed under all circumstances. All warranty rights are invalidated in the event of non-observance. Separate installation instructions are enclosed in the transportation packaging for all additional articles purchased from GRAF.

The components must be checked for any damage prior to installation under all circumstances.

Missing instructions can be downloaded on www.graf.info or can be requested from GRAF.



RAINWATER HARVESTING

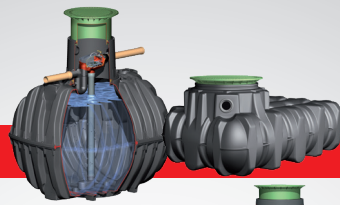

WASTEWATER MANAGEMENT

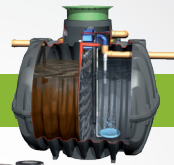

STORMWATER MANAGEMENT



WATER BUTTS & COMPOSTERS



MULTIPURPOSE CONTAINERS



Graf UK Ltd
Regen House
Beaumont Road
Banbury
Oxfordshire OX16 1RH

T: 01608 661500
F: 01295 211333
E: info@grafuk.co.uk
www.grafuk.co.uk

Graf UK Ltd (Scotland)
220 Blairtummock Road
Queenslie Industrial
Estate
Glasgow G33 4ED

T: 0141 465 1540
F: 01295 211333
E: info@grafuk.co.uk
www.grafuk.co.uk