



# Installation manual

**Carat XL Tank**



## 1. GENERAL NOTES

The points described in these instructions must be followed correctly. If not correctly observed, any right to claim on the warranty may be refused.

Any missing instructions must be requested directly from us.

A complete check of all the items/components for possible damage must be carried out before the assembly or installation begins.

The installation must be carried out in a professional manner.

### Safety

The relevant accident prevention regulations must be observed during all work.

The relevant regulations and standards must additionally be taken into consideration during installation, assembly, servicing, repair, etc. Relevant notes can be found in the corresponding sections of these instructions.

During all work on the system or parts of the system, the entire system must always be rendered inoperable and secured to prevent unauthorised reactivation.

Except in the event of work carried out in the tank, the cover of the tank must always be kept sealed, as this otherwise constitutes a maximum risk of accident. The rain protection installed on delivery is merely transportation packaging. It cannot be walked on and is not child-proof; it must be replaced with a suitable cover immediately following delivery (telescopic dome shaft with corresponding cover)! Only original GRAF covers or covers approved in writing by GRAF must be used.

GRAF offers an extensive range of accessories, all of which are designed to match each other and which can be extended to form complete systems. The use of accessories that have not been approved by GRAF results in the exclusion of the warranty/guarantee.

### Identification obligation - Regulation

The water in these systems is not suitable for consumption or personal hygiene.

All pipe-work and outlets of the water systems are to be labelled with the words "Not drinking water" either in words or graphically. (British Standard BS EN 16941-1:2024) so that after years of use, an accidental connection to the drinking water system is prevented. Even when correctly labelled it may possibly be mistaken, for example by children. For this reason, all the outlets of the systems process water must be fitted with child safe valves.

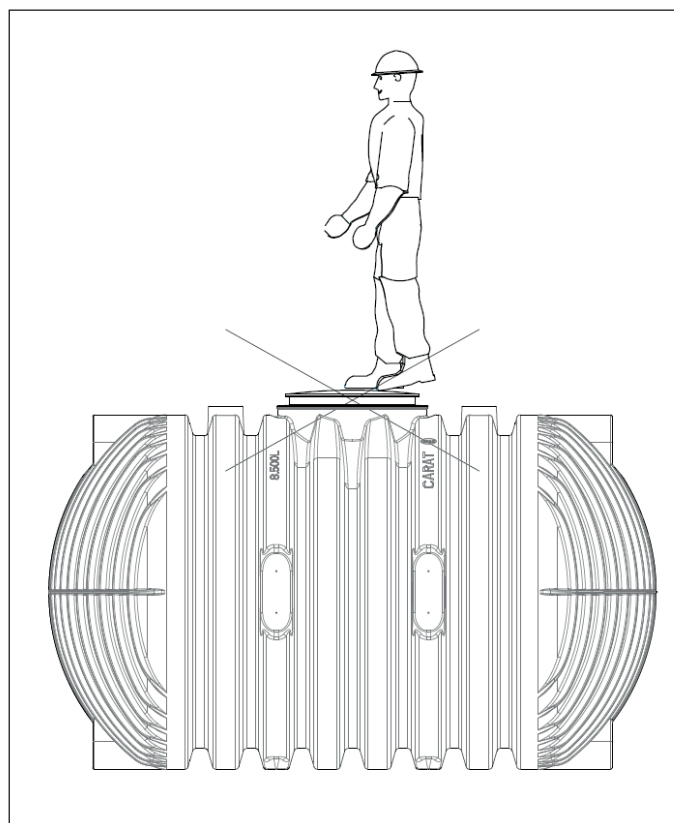

## 2. TECHNICAL DATA

### 2.1 Technical Data Carat XL / Connection option DN160

\* Telescopic dome shaft at maximum height

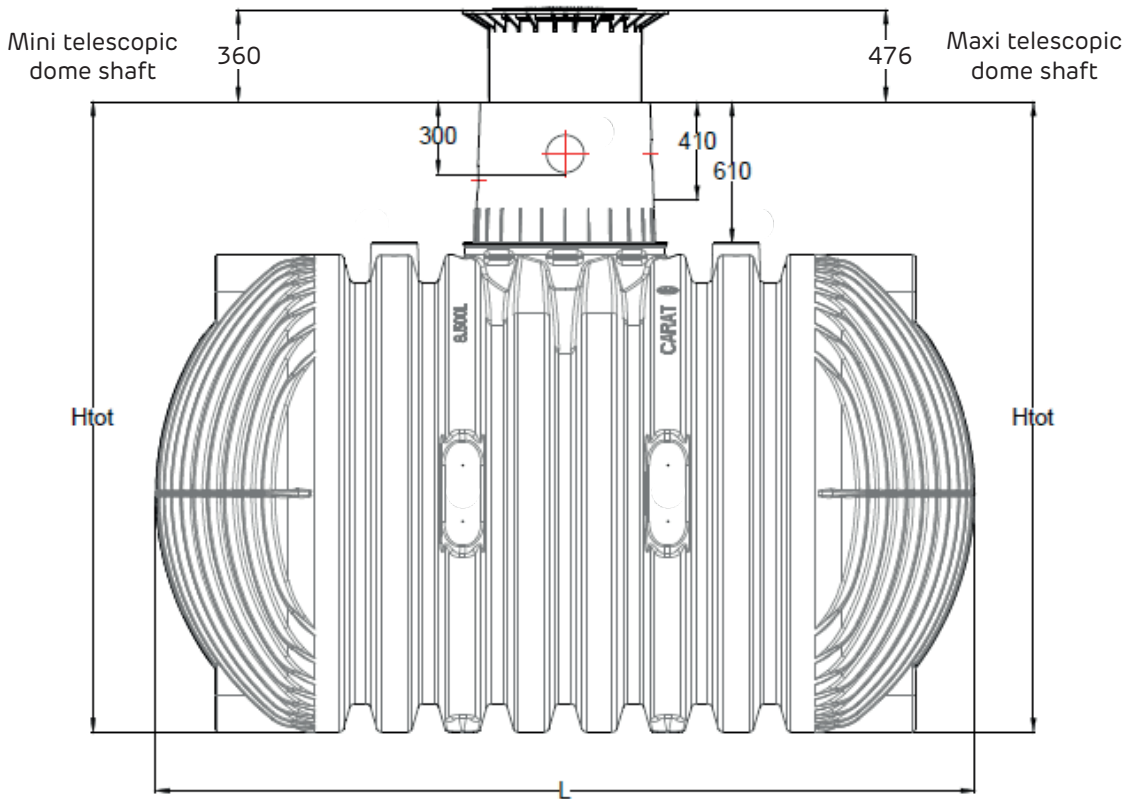

\* Telescopic dome shaft at minimum height

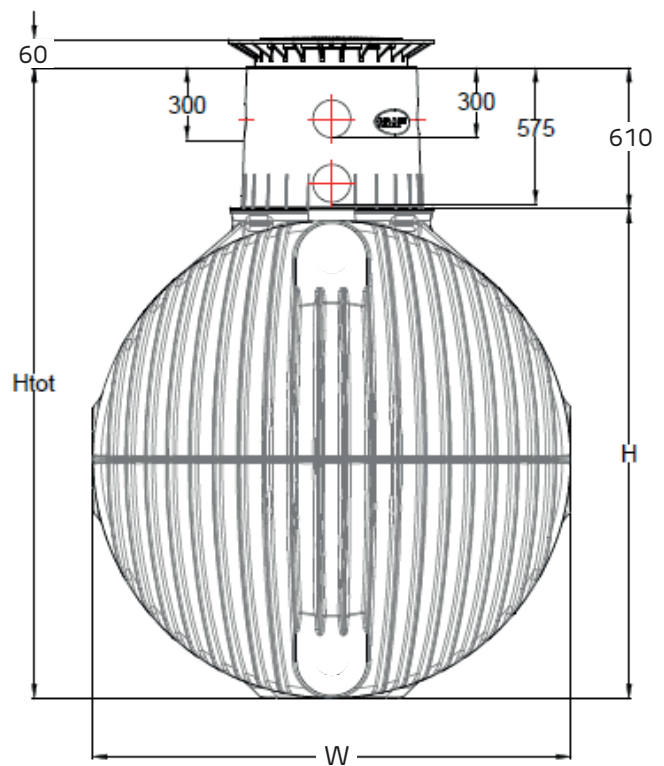

## 2. TECHNICAL DATA

### 2.2 Technical Data Carat XL / Connection option DN110

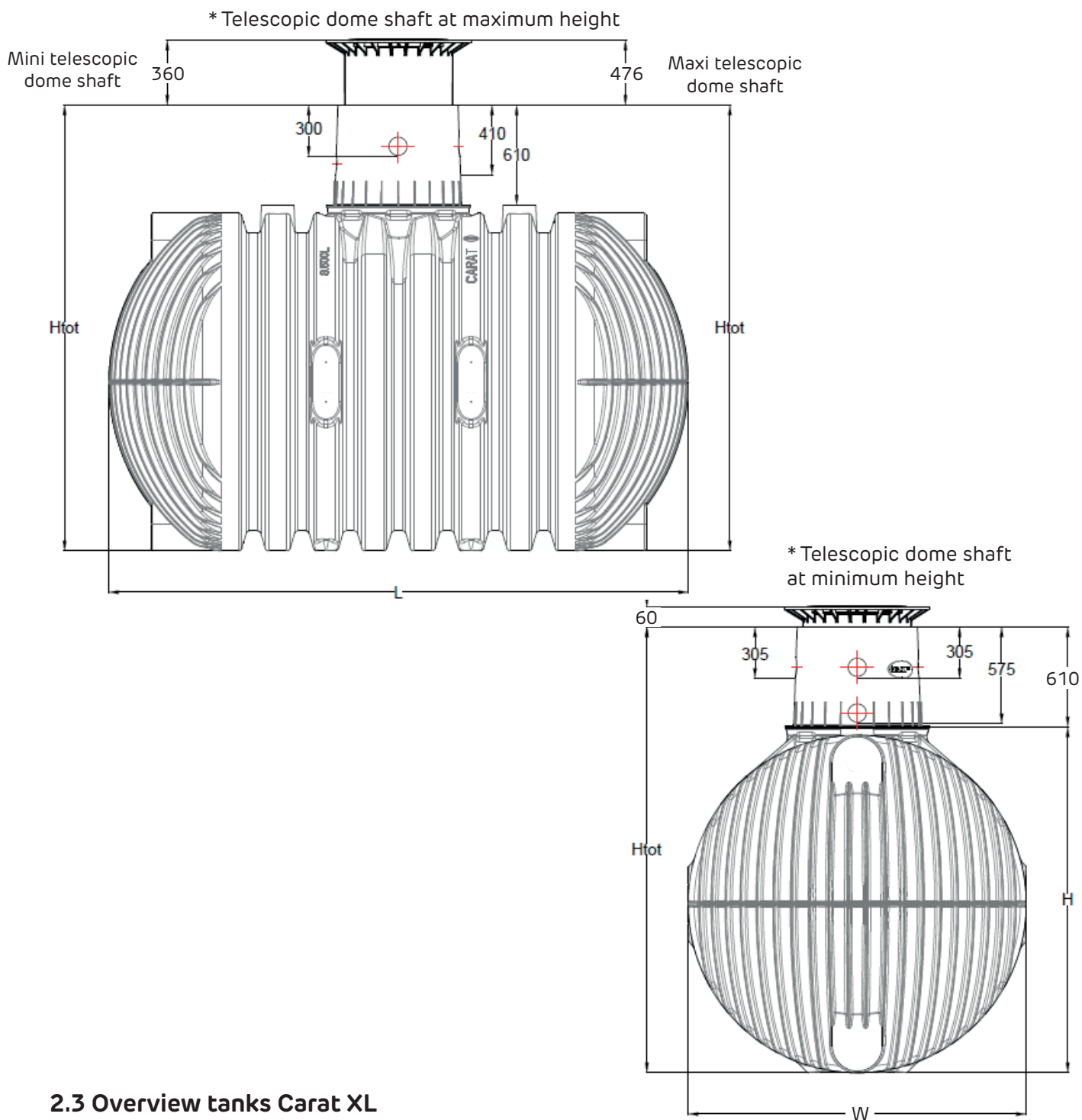

### 2.3 Overview tanks Carat XL

Tank	8500 litres	10000 litres	13000 litres
Art. No.	370014	370015	370046
Weight	380 kg	455 kg	510 kg
L	3500 mm	3520 mm	4000 mm
W	2040 mm	2240 mm	2420 mm
H	2085 mm	2285 mm	2465 mm
$H_{tot}^*$	2695 mm	2895 mm	3075 mm

\*  $H_{tot}$  = total height (without telescopic dome shaft)

### 3. TANK STRUCTURE

1. Cover
2. Telescopic dome shaft (can be inclined by 5°)
3. Profile seal - Telescopic dome shaft
4. Tank dome (can be rotated by 360°)
5. Tank seal - Tank dome
6. Carat XL underground tank

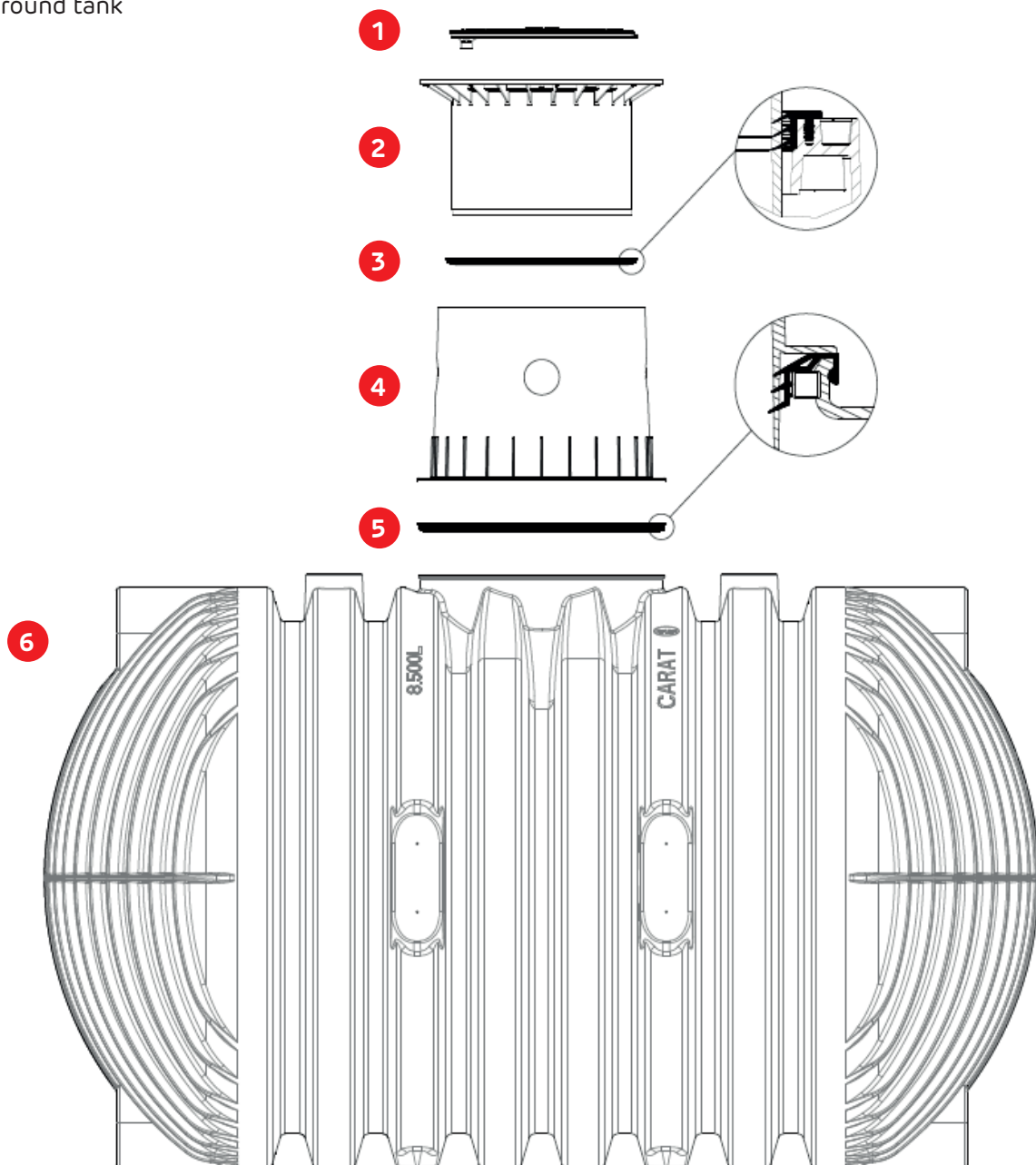





## 4. INSTALLATION AND ASSEMBLY

### 4.2 Trench

To ensure that sufficient space is available for working, the base area of the trench must exceed the dimensions of the tank by > 500mm on each side; the distance from solid structures must be at least 1000mm.

The embankment must be designed according to DIN 4124. The construction site must be horizontal and plane and must guarantee sufficient load-bearing capacity.

The depth of the trench must be dimensioned so that the max. earth coverage (see installation conditions) above the tank is not exceeded. To use the system throughout the entire year, it is necessary to install the tank and those parts of the system which conduct water in a frost-free area. The frost-free depth is usually approx. 600mm - 800mm; precise information in this regard can be obtained from the responsible authority.

A layer of compacted, round-grained gravel (grain size 10/20, thickness approx. 150 - 200mm) is applied as the foundation.

### 4.3 Standard installation overview

Coverage heights with telescopic dome shaft in green areas.

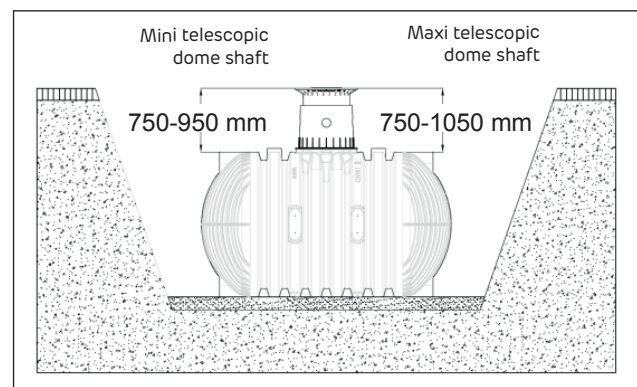

### 4.4 Maximum cover permitted over tank

Maximum coverage heights with extension and telescopic dome shaft.  
(Without groundwater or stratum water)

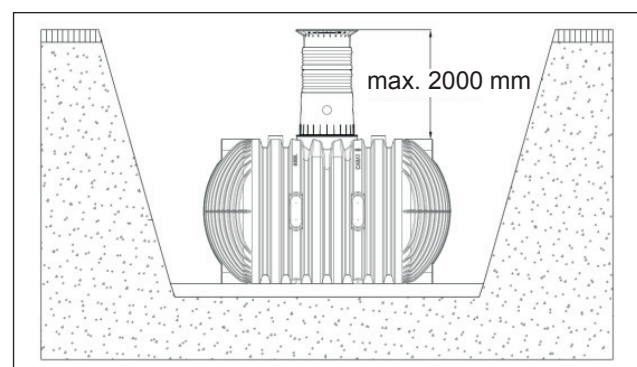

## 4. INSTALLATION AND ASSEMBLY

### 4.5 Slope, embankment, etc.

On installation of the tank in the immediate vicinity (< 5 m) of a slope, earthen mound or slope, a statically calculated supporting wall must be erected to absorb the soil pressure. The wall must exceed the dimensions of the tank by at least 500 mm in all directions, and must be located at least 1000 mm away from the tank.

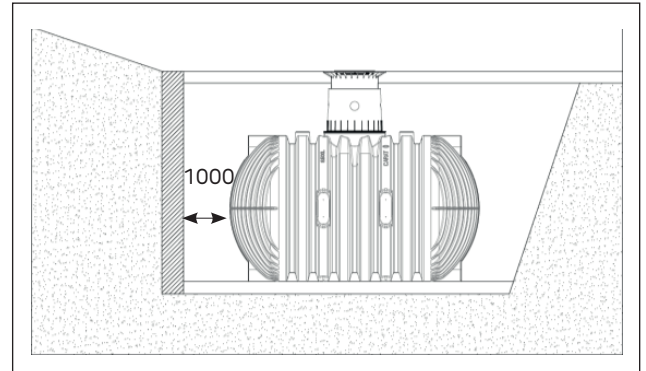

### 4.6 Groundwater and cohesive (water-impermeable) soils (e.g. clay soil)

With only occasional ground water and cohesive, water impermeable soils (e.g. loam), adequate drainage of the ground water or leakage water must be ensured so that the tanks never stand deeper in the ground water than indicated in the table. If necessary, the drainage line must end in a vertical DN 300 pipe in which an immersion pressure pump is installed to pump away the excessive water. The pump must be checked at regular intervals.

If it is to be expected that the tanks could sink lower, adequate drainage must be ensured in all cases. We recommend the general laying of a drainage line, since in the event of prolonged rainfall the ground water level can rise unexpectedly.

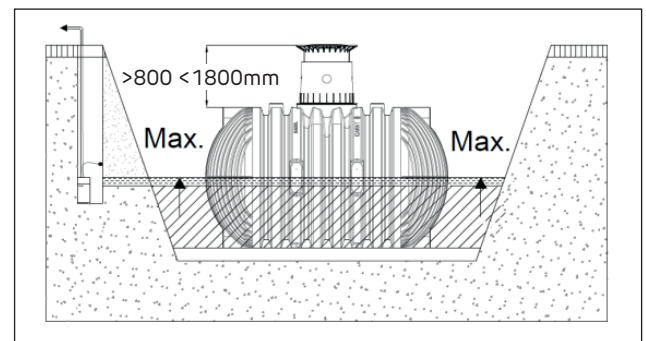

Tank	8500 litres	10000 litres	13000 litres
Max. immersion depth	1042.50 mm	1142.50 mm	1232.50

### 4.7 Installation below light-duty vehicle surfaces

Cover heights with vehicle loading telescopic dome shaft (class B) in area driven over by vehicles up to 3.5 tonnes.  
(Without groundwater or stratum water)

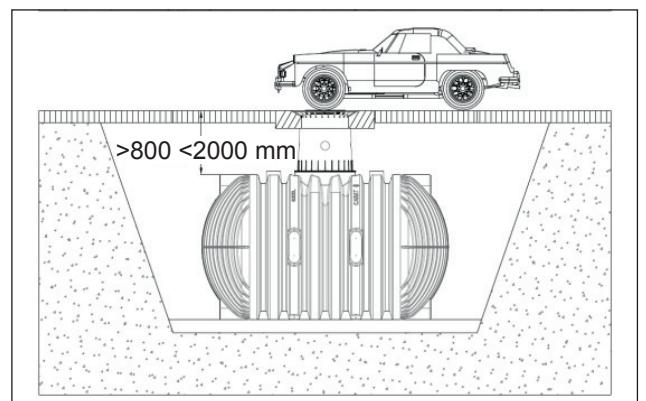



## 4. INSTALLATION AND ASSEMBLY

### 4.8 Installation below heavy-duty vehicle surfaces

Cover heights (with cover class D - to be provided at construction site) in areas used by trucks with a max. weight of 12 t. Without ground water or stratum water.

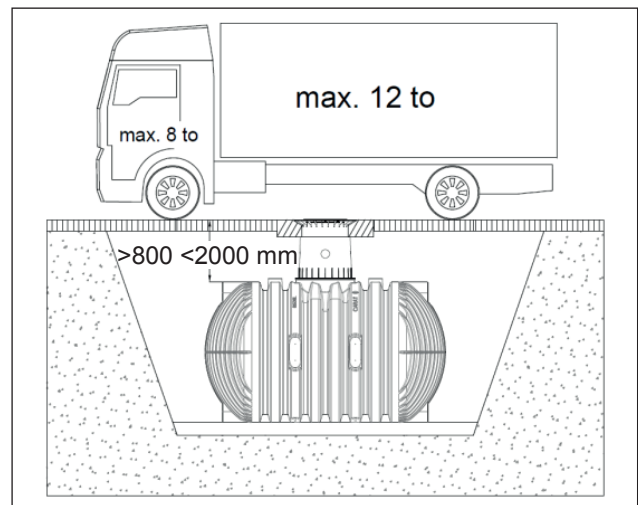

### 4.9 Installation adjacent to surfaces used by vehicles

If the underground tanks are installed adjacent to surfaces which are used by heavy vehicles weighing over 12 t, the minimum distance away from these surfaces is at least the depth of the trench.

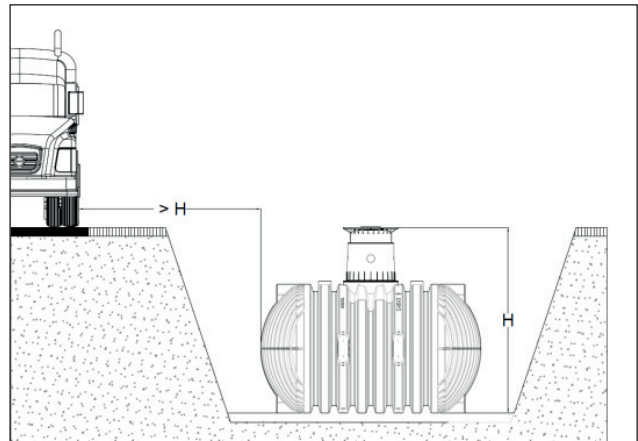

### 4.10 Connection of several tanks

Two or more tanks are connected via the assembly surfaces by means of GRAF special seals DN 110 and basic pipes (to be provided at construction site).

The apertures must be drilled to the corresponding size using only the GRAF special crown bit. It must be ensured that the distance between the tanks is at least 600 mm. The pipes must project 100 mm - 150 mm into the tanks.

**Please note that the lower openings of the tanks (10.000L) are offset to the side, not in the middle. Attention must therefore be paid even when positioning the tanks that the openings are located so as to correspond with one another.**

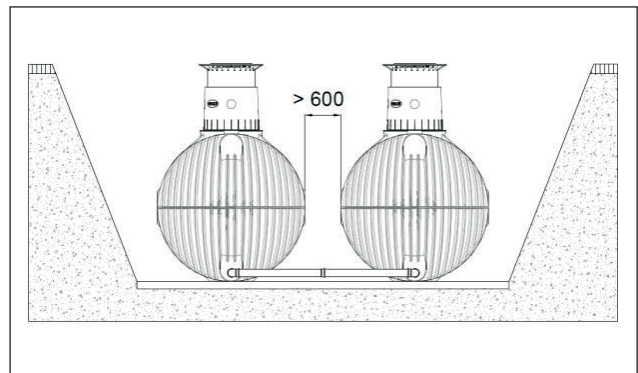

## 4. INSTALLATION AND ASSEMBLY

### 4.11 Insertion and filling

The tanks must be inserted, impact-free, into the prepared trench using suitable equipment. To avoid deformities, the tank is filled approx. 25 cm with water before filling in the tank surrounding.

Afterwards the surrounding (roundgrain gravel, max. grain size 10/20) is then filled in layers of max. 40 cm steps and is compacted.

The individual layers must be well-compacted (manual tamper). Damage to the tank must be avoided during compaction. Mechanical compaction machines must not be used under any circumstances. The surrounding must be at least 500 mm wide.

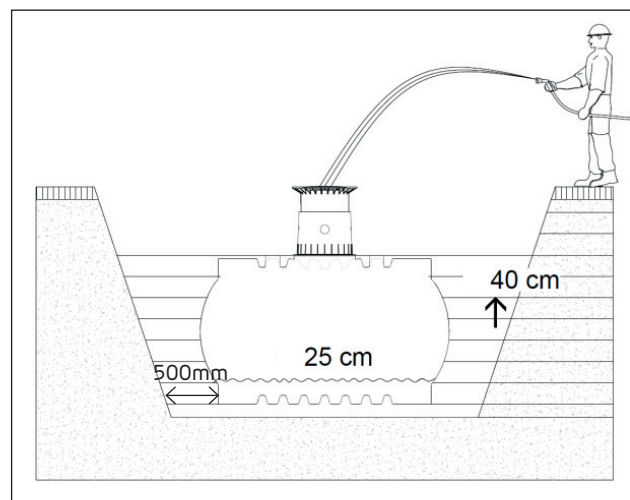

### 4.12 Routing connections

All feed and overflow pipes must be routed with a decline of at least 1% in the direction of flow (possible, subsequent settling must be taken into consideration in this case). If the tank overflow is connected to a public sewer, this must be protected against reflux by means of a lifting station (mixed sewer) or reflux seal (pure rainwater sewer) according to DIN 1986.

All suction, pressure and control lines must be routed in an empty pipe, which must be routed as straight as possible, without bending, to the tank with a decline. Necessary bends must be formed using 30° moulded sections.

**Important:** The empty pipe must be connected to an aperture **above** the max. water level.

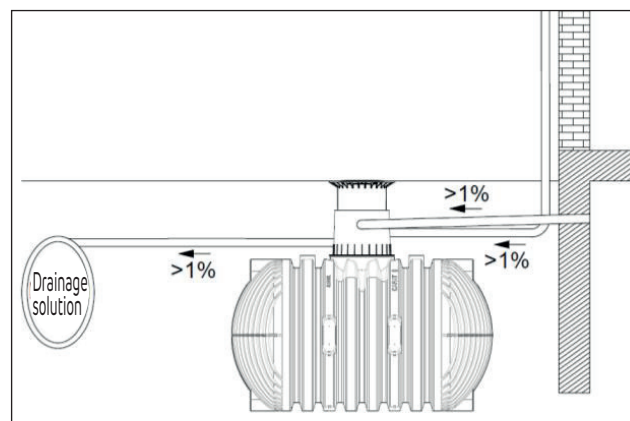

### 4.13 Routing connections - specific to Wastewater applications

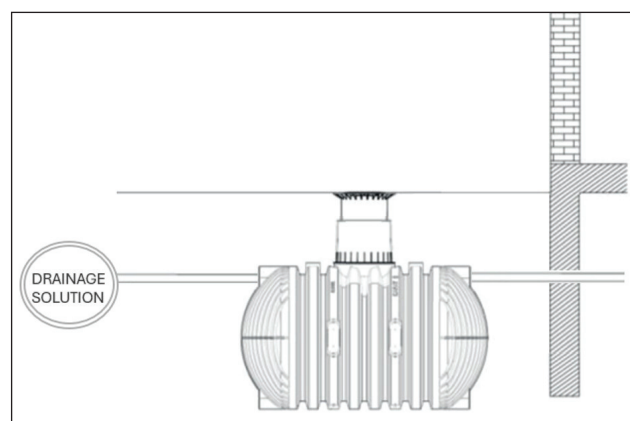

## 5. ASSEMBLING THE TELESCOPIC DOME SHAFT

### 5.1 Assembling the tank dome

Prior to assembly, the enclosed seal is locked onto the tank neck's profile „B“. The tank dome is then aligned with the piping connections and is locked to the tank neck. It is essential to make sure that the upper seal "A" (pre-assembled) is correctly installed.

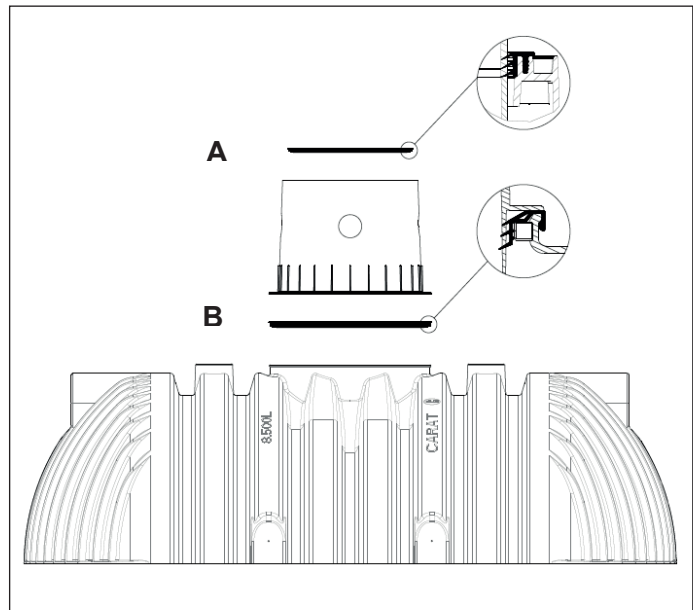
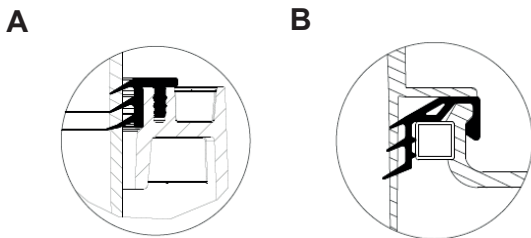

### 5.2 Assembling the telescopic dome shaft

The telescopic dome shaft enables infinite adaptation of the tank to given site surfaces with earth coverage of between 750mm and 950mm (mini telescopic dome shaft) or 750mm and 1050mm (maxi telescopic dome shaft).

For assembly purposes, the enclosed profile seal (material EPDM) is inserted into the tank dome's sealing groove and is coated generously with soft soap (do not use mineral oil-based lubricants, as these attack the seal). The telescopic dome shaft is then greased, inserted and aligned with the surface of the site.

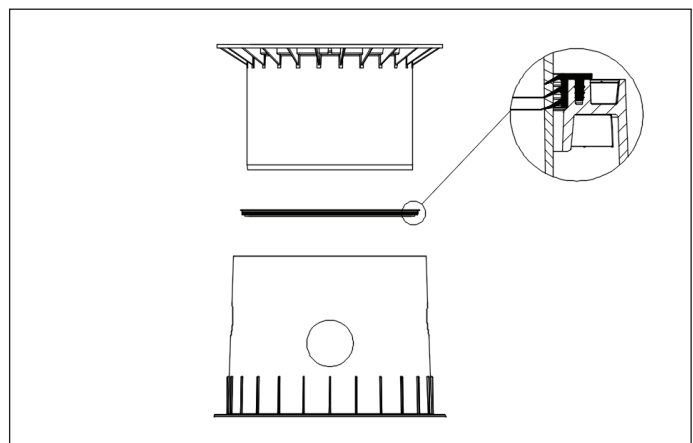

### 5.3 Telescopic dome shaft on which persons may walk

**Important:** To prevent loads from being transferred onto the tank, round-grain gravel **2** (max. grain size 10/20) is filled in in layers around the telescopic dome shaft **1** and is evenly compacted. Damage to the tank dome **3** and telescopic dome shaft must be avoided during this step. The cover is then positioned and is sealed to prevent entry by children. **Tighten the threaded connection on the cover so tightly that it cannot be opened by a child!**

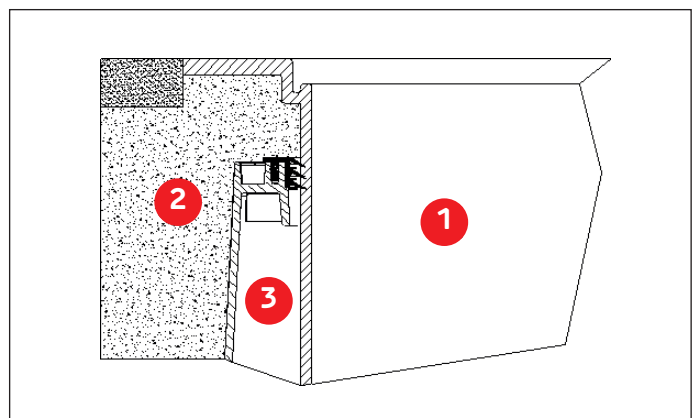

## 5. ASSEMBLING THE TELESCOPIC DOME SHAFT

### 5.4 Telescopic dome shaft over which passenger cars may drive

If the tank is installed under areas used by passenger cars, the collar area of the telescopic dome shaft **1** (colour anthracite) must be supported with concrete **4** (load class B25 = 250 kg/m<sup>2</sup>). The layer of concrete to be installed must be at least 400 mm wide and approx. 200 mm high all around. The minimum coverage above the shoulder of the tank is at least 800 mm (max. 1050 mm with telescopic dome shaft, coverage up to max. 2000 mm possible with extension).

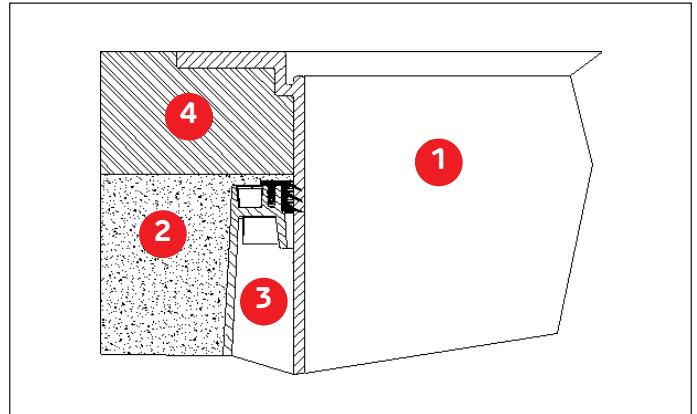

### 5.5 Telescopic dome shaft for HGV loading

When installing below surfaces driven on by HGVs, the telescopic dome shaft is lined **1** as described in 5.4. The concrete rings **6** (diameter 600mm) and a cast frame **5** with star-shaped load distribution are then installed to support the cast cover. The cast frame must have a contact area of approx. 1m<sup>2</sup>.

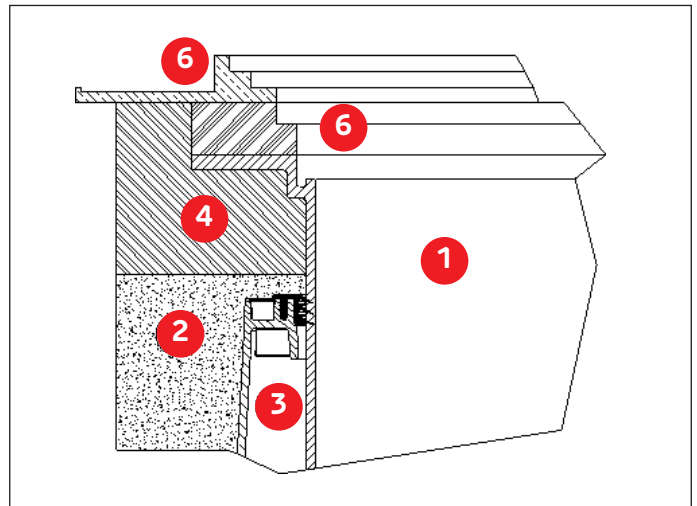

### 5.6 Assembling the extension

For larger coverage heights an extension is needed. To insert the extension into the tank dome, soft soap is needed. Into the highest groove of the extension the profile seal is inserted and greased generously. Afterwards push the telescopic dome shaft onto the extension and adjust it to the planned area surface.

#### max. earth-cover 2000mm

(in each case in connection with the Maxi telescopic dome shaft).

- 1** Telescopic dome shaft (can be inclined by 5°)
- 2** Extension
- 3** Tank dome (can be rotated by 360°)

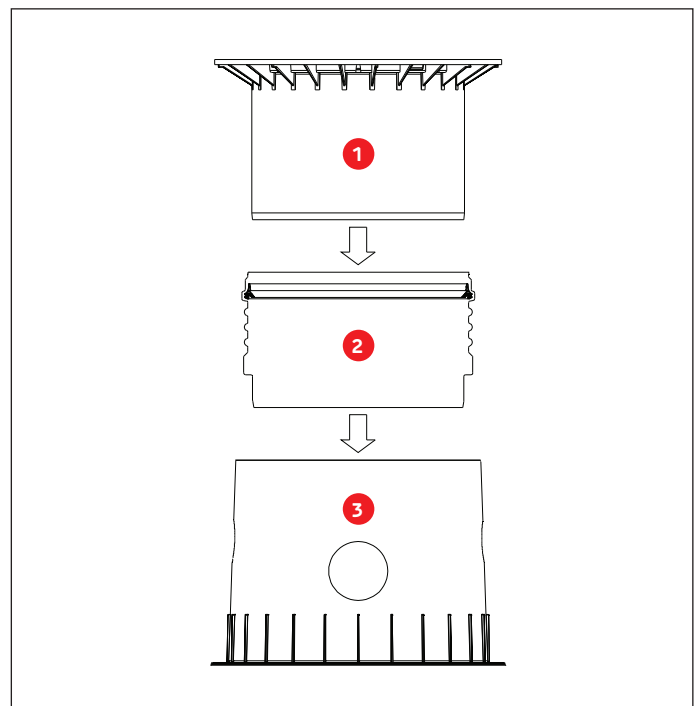

## 6. INSPECTION AND SERVICING

The entire system must be checked for leaks, cleanliness and stability at least every three months.

The entire system should be serviced at intervals of approx. 5 years. In this case, all parts of the system must be cleaned and their function checked. Servicing should be carried out as follows:

- Drain the tank completely
- Clean surfaces and internal parts with water
- Remove all dirt from the tank
- Check that all internal parts are firmly connected.

**The points described in these instructions must be observed under all circumstances. All warranty rights are invalidated in the event of non-observance. Separate installation instructions are enclosed in the transportation packaging for all additional articles purchased from GRAF.**

**The components must be checked for any damage prior to installation under all circumstances.**

**Missing instructions can be downloaded on [www.graf.info](http://www.graf.info) or can be requested from GRAF.**









RAINWATER HARVESTING

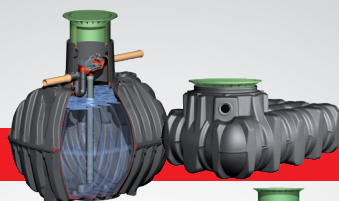

WASTEWATER MANAGEMENT



STORMWATER MANAGEMENT



WATER BUTTS & COMPOSTERS



MULTIPURPOSE CONTAINERS



**Graf UK Ltd**  
Regen House  
Beaumont Road  
Banbury  
Oxfordshire OX16 1RH

T: 01608 661500  
F: 01295 211333  
E: [info@grafuk.co.uk](mailto:info@grafuk.co.uk)  
[www.grafuk.co.uk](http://www.grafuk.co.uk)

**Graf UK Ltd (Scotland)**  
220 Blairtummock Road  
Queenslie Industrial  
Estate  
Glasgow G33 4ED

T: 0141 465 1540  
F: 01295 211333  
E: [info@grafuk.co.uk](mailto:info@grafuk.co.uk)  
[www.grafuk.co.uk](http://www.grafuk.co.uk)