



Installation manual

Platin XL Tank



1. GENERAL NOTES

The points described in these instructions must be followed correctly. If not correctly observed, any right to claim on the warranty may be refused.

Any missing instructions must be requested directly from us.

A complete check of all the items/components for possible damage must be carried out before the assembly or installation begins.

The installation must be carried out in a professional manner.

Safety

The relevant accident prevention regulations must be observed during all work.

The relevant regulations and standards must additionally be taken into consideration during installation, assembly, servicing, repair, etc.

The system or individual parts of the system must be installed by qualified specialists.

During all work on the system or parts of the system, the entire system must always be rendered inoperable and secured to prevent unauthorised reactivation.

Except in the event of work carried out in the tank, the cover of the tank must always be kept sealed, as this otherwise constitutes a maximum risk of accident. Only original GRAF covers or covers approved in writing by GRAF must be used.

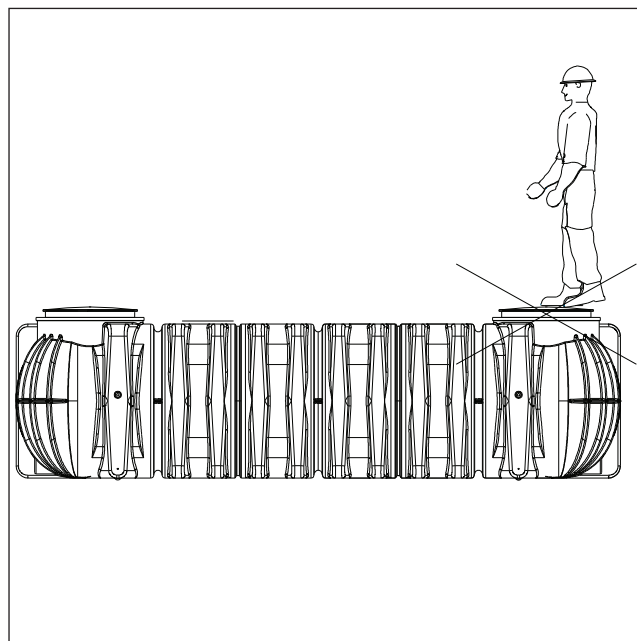

GRAF offers an extensive range of accessories, all of which are designed to match each other and which can be extended to form complete systems. The use of accessories that have not been approved by GRAF results in the exclusion of the warranty/guarantee.

Identification obligation - Regulation

The water in these systems is not suitable for consumption or personal hygiene.

All pipe-work and outlets of the water systems are to be labelled with the words "Not drinking water" either in words or graphically. (British Standard BS EN 16941-1:2024) so that after years of use, an accidental connection to the drinking water system is prevented. Even when correctly labelled it may possibly be mistaken, for example by children. For this reason, all the outlets of the systems process water must be fitted with child safe valves.

2. TECHNICAL DATA

2.1 Technical Data Platin XL / Connection option DN150

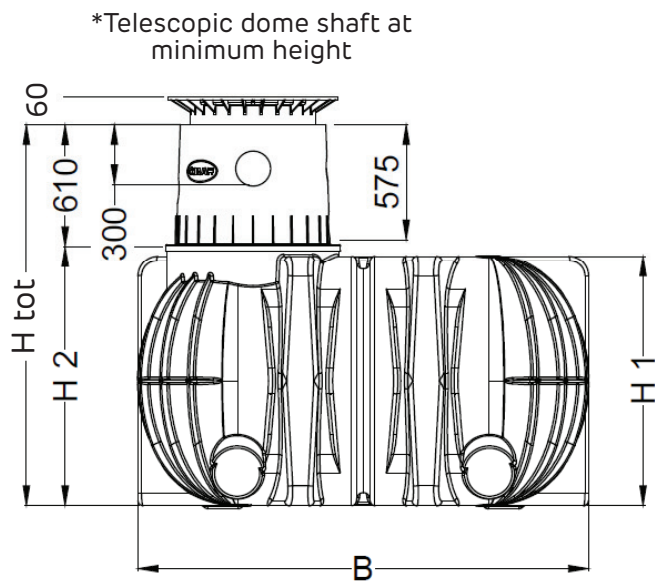
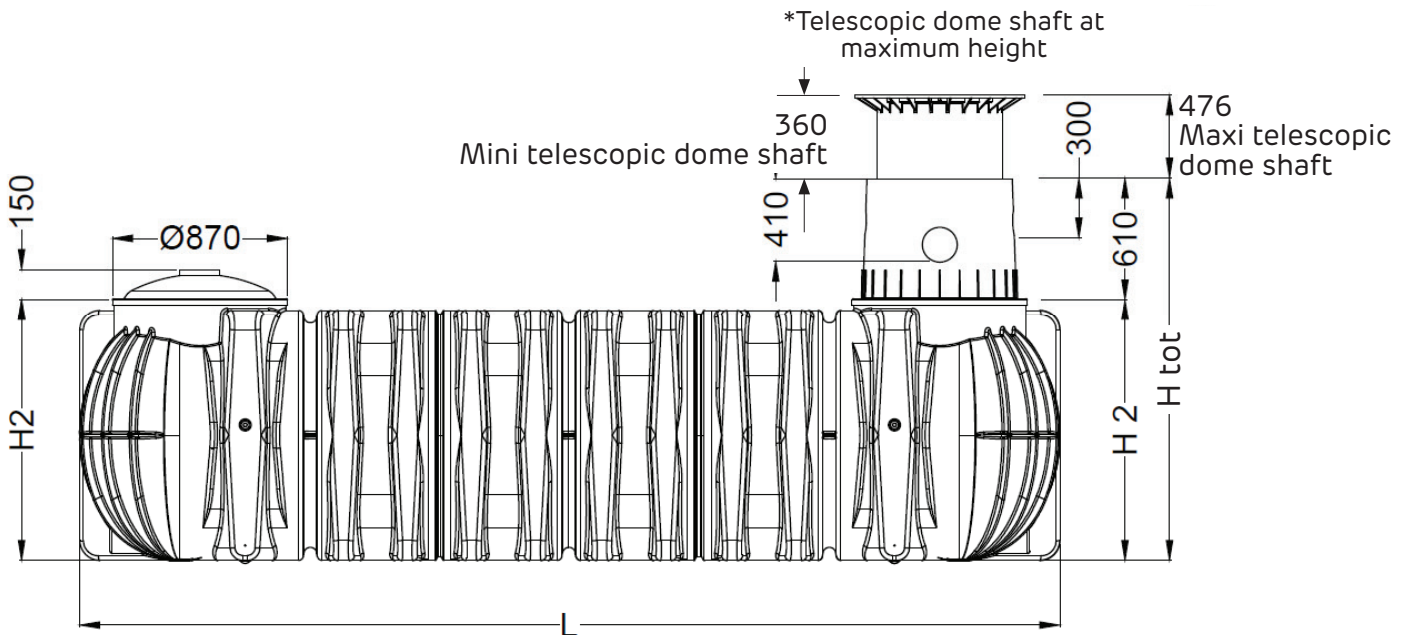

2.2 Overview tanks Platin XL

Tank	10,000 litres	15,000 litres
Art. No.	390006	390007
Weight	460 kg	710 kg
L	4900 mm	7500 mm
W	2250 mm	2250 mm
H ₁	1250 mm	1250 mm
H ₂	1300 mm	1300 mm
Htot*	1910 mm	1910 mm

* Htot = total height (without telescopic dome shaft)

2. TECHNICAL DATA

2.3 Technical Data Platin XL / Connection option DN100

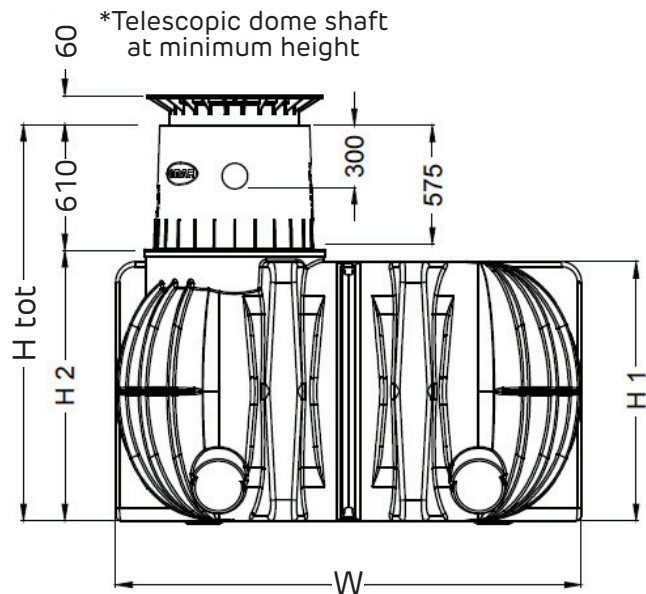
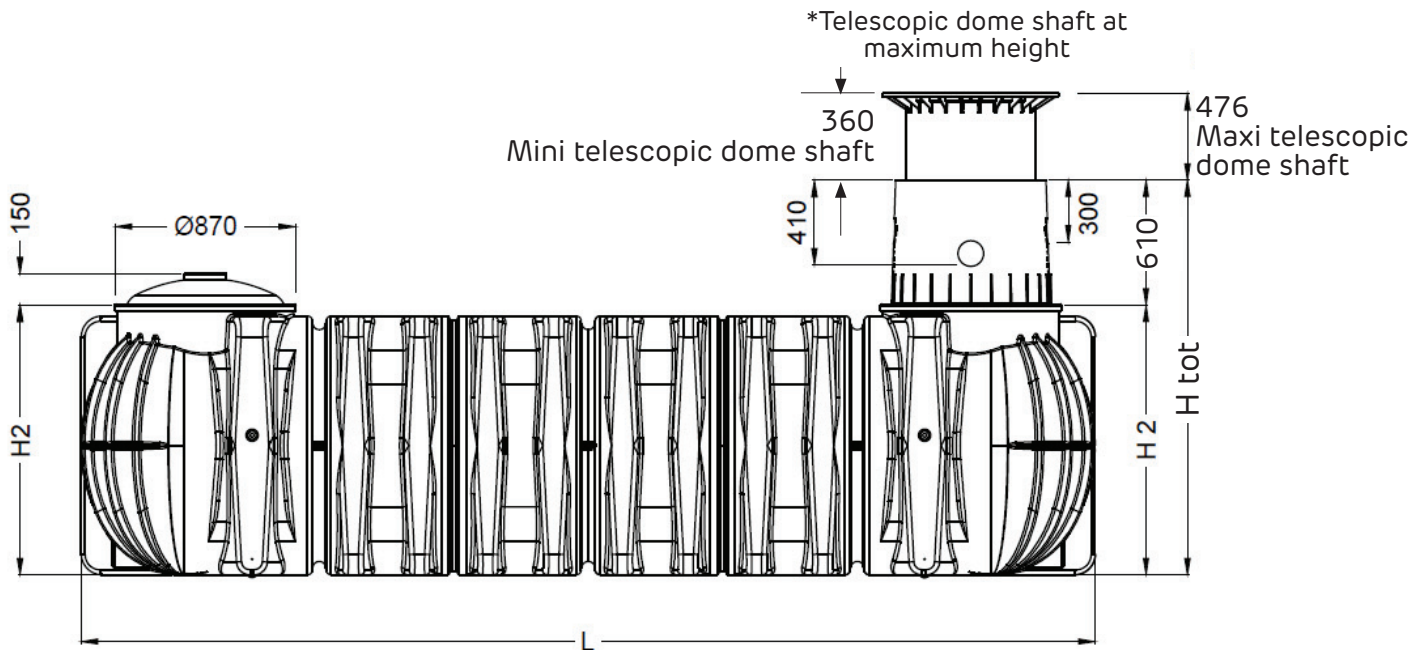

2.4 Overview tanks Platin XL

Tank	10,000 litres	15,000 litres
Art. No.	390016	390017
Weight	460 kg	710 kg
L	4900 mm	7500 mm
W	2250 mm	2250 mm
H ₁	1250 mm	1250 mm
H ₂	1300 mm	1300 mm
Htot*	1910 mm	1910 mm

* Htot = total height (without telescopic dome shaft)

3. TANK STRUCTURE

1. Cover
2. Telescopic dome shaft (can be inclined by 5°)
3. Profile seal - Telescopic dome shaft
4. Tank dome (can be rotated by 360°)
5. Tank seal - Tank dome
6. Tank dome sealing plug
7. Platin XL tank

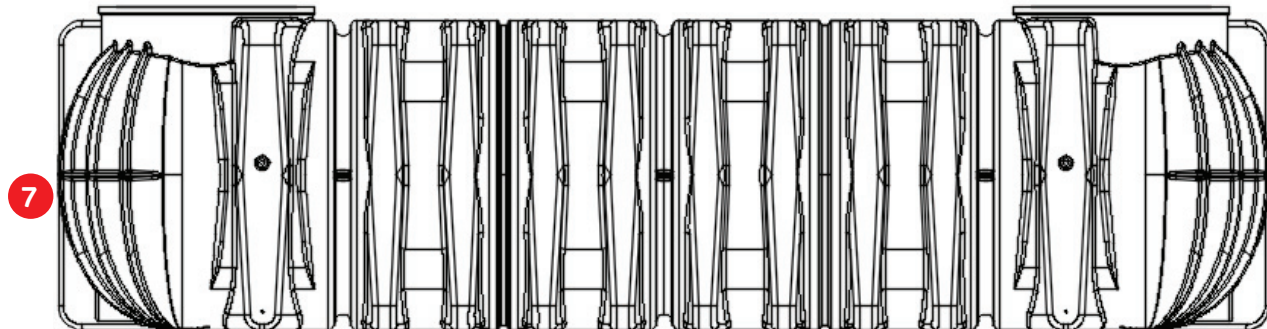
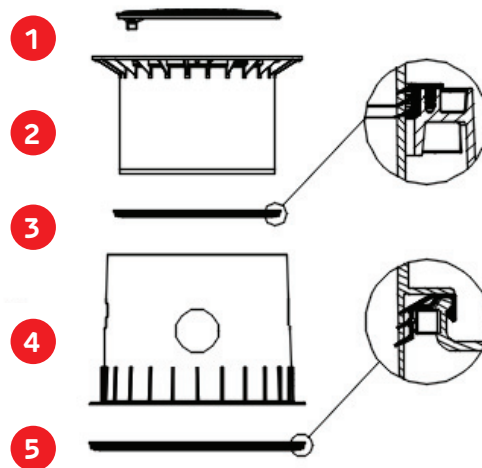
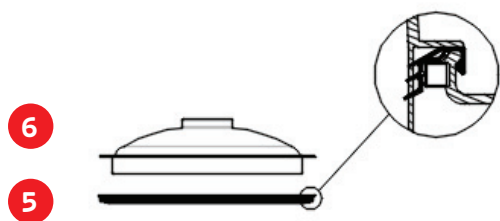

4. INSTALLATION AND ASSEMBLY

4 Installation conditions

1. Subsoil
 2. Telescopic dome shaft
 3. Compact foundation
 4. Surrounding (round-grained gravel, maximum grain size 10/20)
 5. Covering layer
 6. Platin XL Underground Tank
 7. Concrete layer for surfaces used by passenger cars
- B** --> DIN 4124 from 1250mm depth of the trench

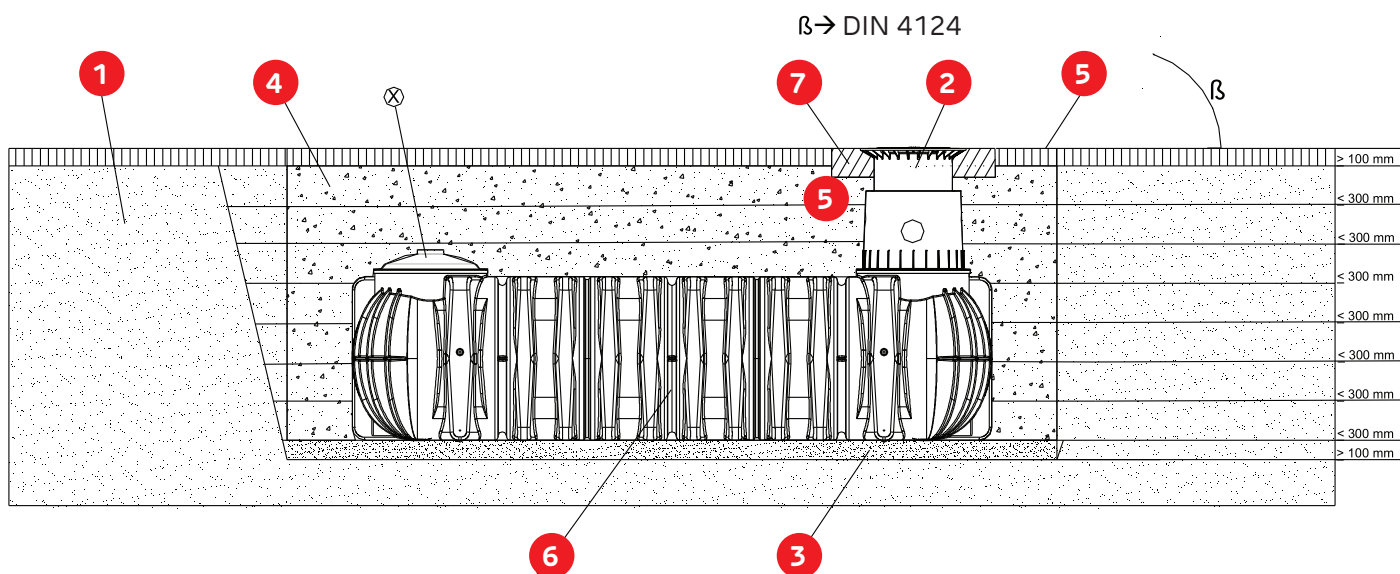

4.1 Construction site

Under all circumstances, the following points must be clarified prior to installation:

- The structural suitability of the ground according to DIN 18196
- Maximum groundwater levels which occur and drainage capability of the subsoil
- Types of load which occur, e.g. traffic loads

An expert ground report should be requested from the local planning authority to determine the physical characteristics of the subsoil.

4.2 Trench

To ensure that sufficient space is available for working, the base area of the trench must exceed the dimensions of the tank by > 100mm on each side; the distance from the solid structures must be at least 1000mm.

If the depth of the trench is > 1250mm an embankment must be designed according to DIN 4124. The construction site must be horizontal and plane and must guarantee sufficient load-bearing capacity.

The depth of the trench must be dimensioned so that the max. earth coverage (see installation conditions) above the tank is not exceeded. To use the system throughout the entire year, it is necessary to install the tank and those parts of the system which conduct water in a frost-free area. The frost-free depth is usually approx. 600mm - 800mm; precise information in this regard can be obtained from the responsible authority.

A layer of compacted, round-grained gravel (grain size 10/20, thickness approx. 100 - 150mm) is applied as the foundation.

4. INSTALLATION AND ASSEMBLY

4.3 Standard installation overview

Coverage heights with telescopic dome shaft in green areas.

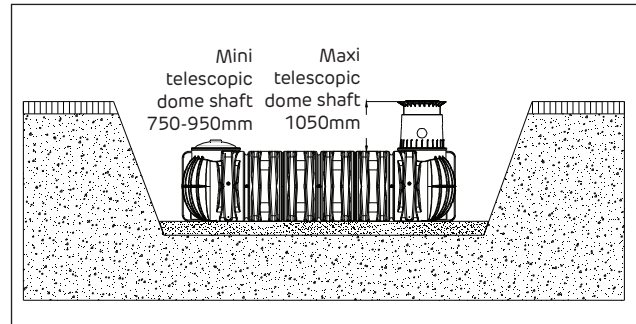

4.4 Maximum cover permitted over tank

Maximum coverage heights with extension and telescopic dome shaft. (in green areas only- not under passable areas)

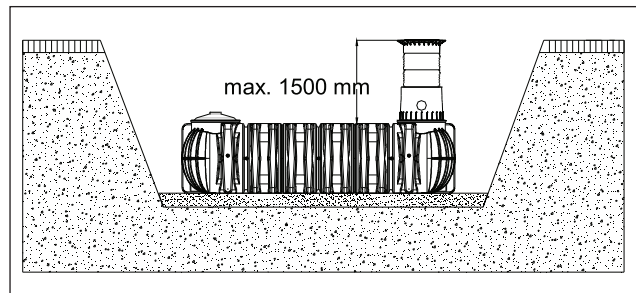

4.5 Slope, embankment, etc.

On installation of the tank in the immediate vicinity (< 5m) of a slope, earthen mound or slope, a statically calculated supporting wall must be erected to absorb the soil pressure. The wall must exceed the dimensions of the tank by at least 500mm in all directions, and must be located at least 1000mm away from the tank.

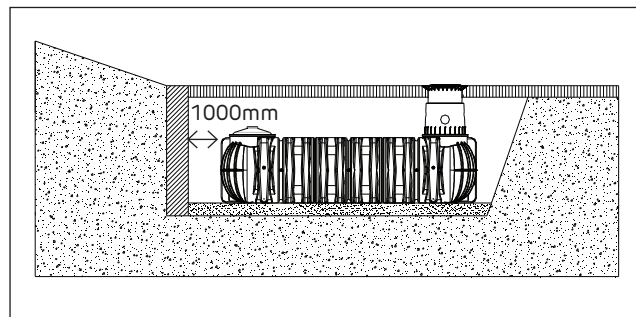

4.6 Groundwater and cohesive (water-impermeable) soils (e.g. clay soil)

Coverage heights on installation in groundwater - the hatched area specifies the permissible immersion depth of the tank. (Not under passable areas)

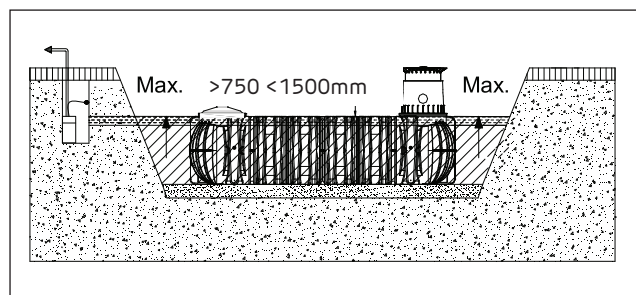

4.7 Groundwater and cohesive (water-impermeable) soils (e.g. clay soil)

If it is anticipated that the tanks will be immersed deeper into the groundwater than is shown in the adjacent figure, sufficient dissipation must be ensured. (See table for max. immersion depth). Dissipation of the drainage water (e.g. via an annular drainage system) is recommended in the case of cohesive, water-impermeable soils.

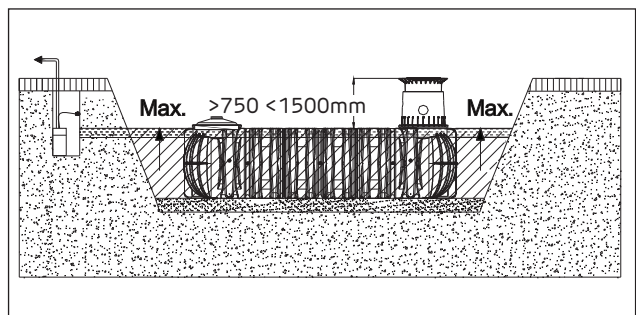

Tank	10000 litres	15000 litres
Max. immersion depth	1250 mm	1250 mm

4. INSTALLATION AND ASSEMBLY

4.8 Installation below light duty vehicle surfaces

Cover heights with vehicle loading telescopic dome shaft (class B) in area driven over by vehicles up to 3,5 tonnes.

(Without groundwater or stratum water)

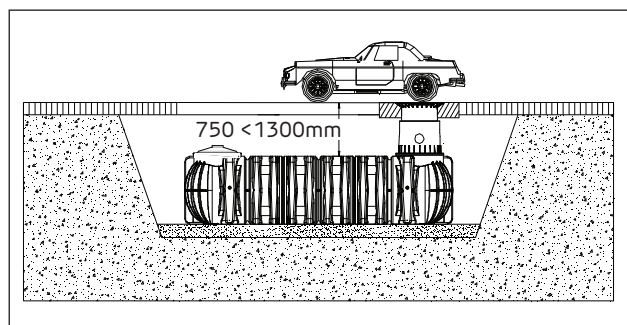

4.9 Installation below HGV bearing surfaces

The shaft can only be driven over with HGVs in conjunction with a self-supporting, iron reinforced concrete plate. To ensure that no additional forces or effects of HGV-bearing are transferred to the tanks, the dimensions and strength of the concrete plate must be statically calculated.

If you have any questions in this regard, please contact your Graf UK team.

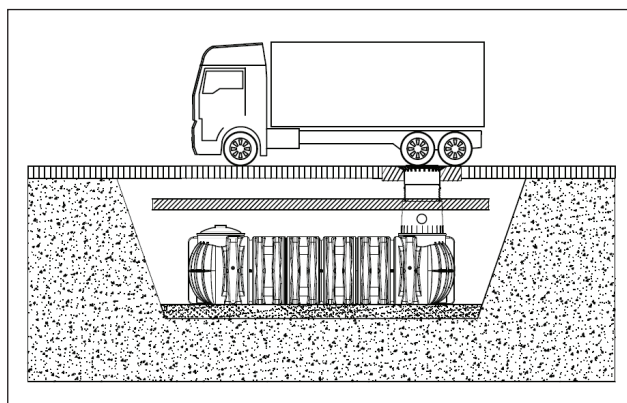

4.10 Installation adjacent to surfaces used by vehicles

If the underground tanks are installed adjacent to surfaces which are used by heavy vehicles weighing over 3,5t, the minimum distance away from these surfaces is at least the depth of the trench.

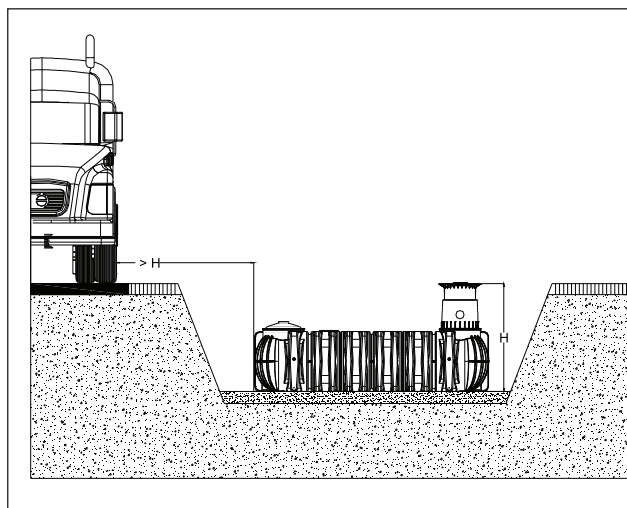

4. INSTALLATION AND ASSEMBLY

4.11 Connection of several tanks

Two or more tanks are connected via the assembly surfaces by means of GRAF special seals and basic pipes (to be provided at the construction site).

The apertures must be drilled to the corresponding size using only the GRAF special crown bit.

It must be ensured that the distance between the tanks is at least 600mm. The pipes must project at least 200mm into the tanks.

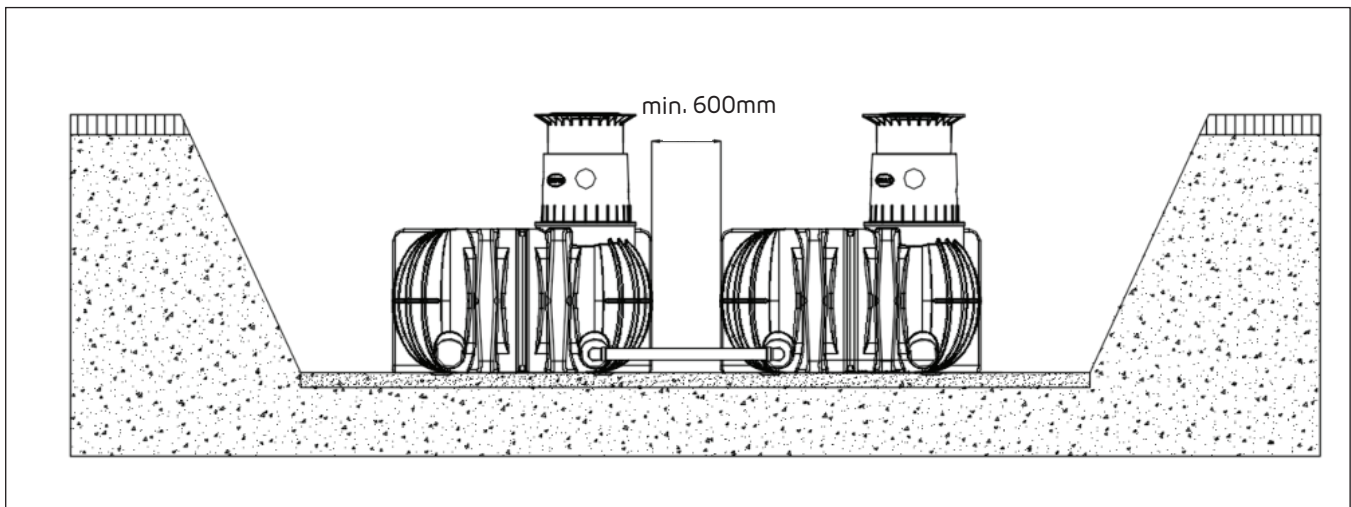

4. INSTALLATION AND ASSEMBLY

4.12 Insertion and filling

The tanks must be inserted, impact-free, into the prepared trench using suitable equipment. To avoid deformities, the tank is filled 1/3 with water before filling in the tank surrounding.

Afterwards the surrounding (roundgrain gravel, max. grain size 10/20) is then filled in layers of max. 30cm steps and is compacted.

The individual layers as well as the medial support column must be well compacted (manual tamper).

Damage to the tank must be avoided during compaction. Mechanical compaction machines must **not** be used under any circumstances. The surrounding towards the trench must be at least 100mm wide.

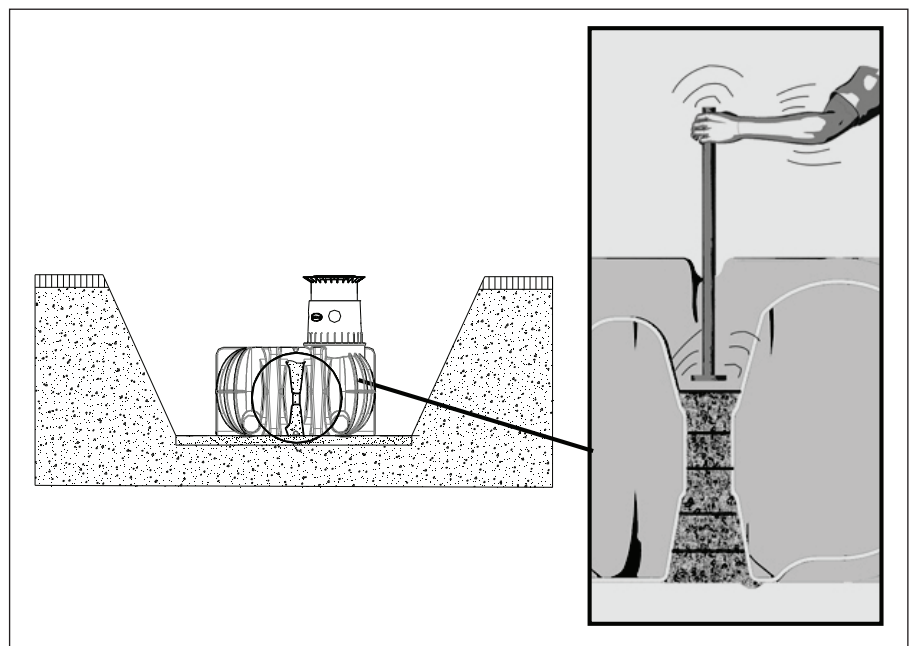
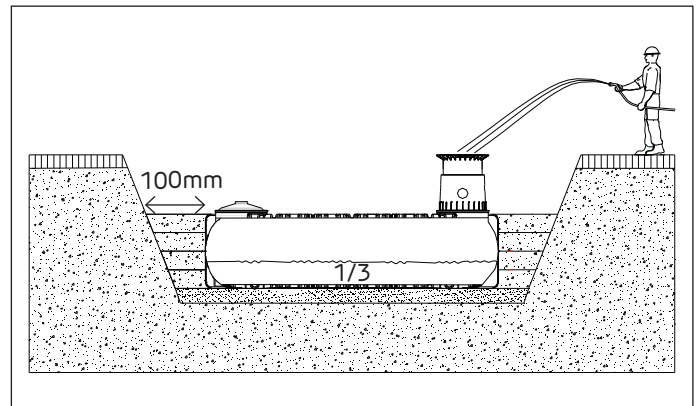

4.13 Routing connections

All feed and overflow pipes must be routed with a decline of at least 1% in the direction of flow (possible, subsequent settling must be taken into consideration in this case). If the tank overflow is connected to a public sewer, this must be protected against reflux by means of a lifting station (mixed sewer) according to DIN 1986.

All suction, pressure and control lines must be routed in an empty pipe, which must be routed as straight as possible, without bending, to the tank with a decline. Necessary bend must be formed using 30° moulded sections.

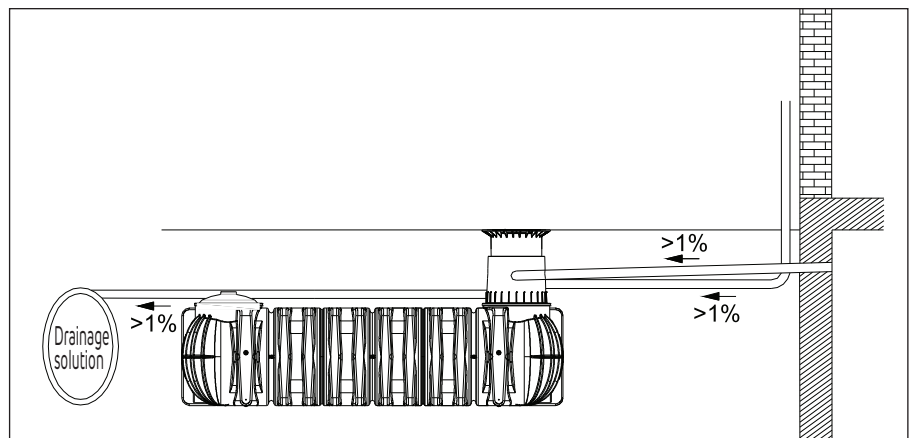

Important: The empty pipe must be connected to an aperture **above the max. water level**.

5. ASSEMBLING THE TELESCOPIC DOME SHAFT

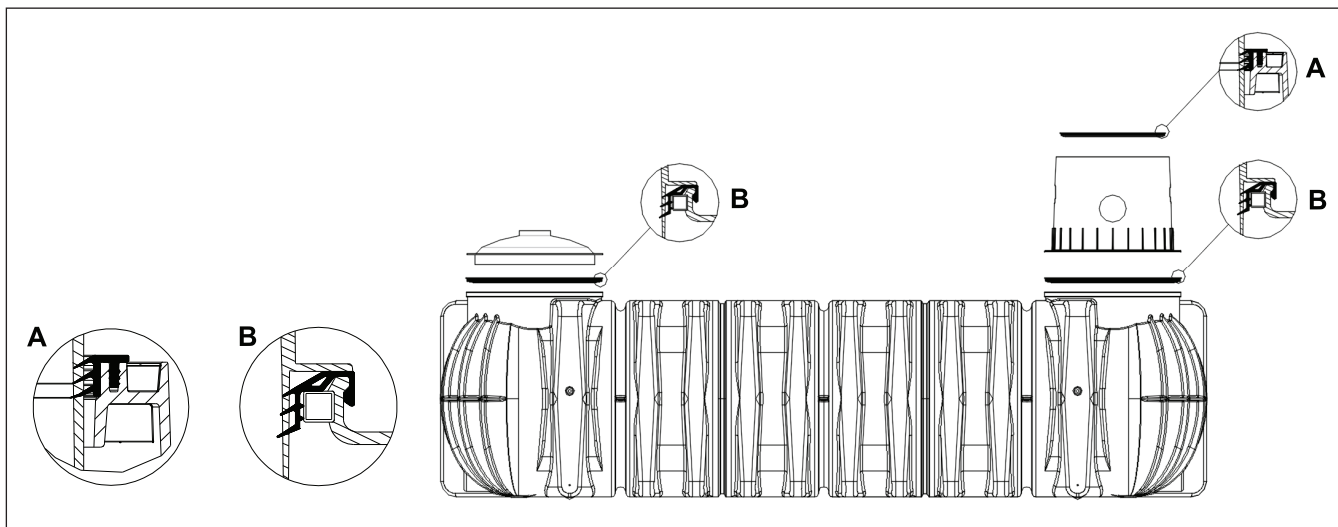

5.1 Assembling the tank dome

Prior assembly, the enclosed seal is locked onto the tank neck's profile "B". The tank dome is then locked to the tanks neck. It is essential to make sure that the upper seal "A" (pre-assembled) is correctly installed.

5.2 Assembling the telescopic dome shaft

The telescopic dome shaft enables infinite adaptation of the tank to given site surfaces with earth coverage of between 750mm and 950mm (mini telescopic dome shaft) or 750mm and 1050mm (maxi telescopic dome shaft).

For assembly purposes, the enclosed profile seal (material EPDM) is inserted into the tank dome's sealing groove and is coated generously with soft soap (do not use mineral oil-based lubricants, as these attack the seal). The telescopic dome shaft is then greased, inserted and aligned with the surface of the site.

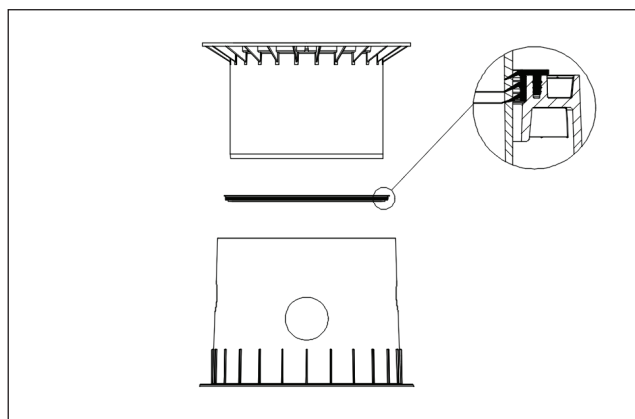

5.3 Telescopic dome shaft on which persons may walk

Important: To prevent loads from being transferred onto the tank, round-grain gravel **2** (max. grain size 10/20) is filled in layers around the telescopic dome shaft **1** and is evenly compacted. Damage to the tank dome **3** and telescopic dome shaft must be avoided during this step. The cover is then positioned and is sealed to prevent entry by children. **Tighten the threaded connection on the cover so tightly that it cannot be opened by a child!**

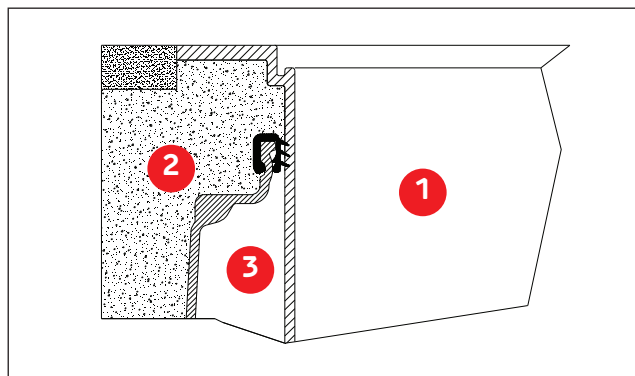

5. ASSEMBLING THE TELESCOPIC DOME SHAFT

5.4 Telescopic dome shaft over which passenger cars may drive

If the tank is installed under areas used by passenger cars, the collar area of the telescopic dome shaft **1** (colour anthracite) must be supported with concrete **4** (load class B25 = 250kg/m²). The layer of concrete to be installed must be at least 300mm wide and approx. 200mm high all round. The permitted coverage above the shoulder of the tank is min. **750mm** and max. **1300mm**. There are different possibilities for lengthening the tank dome (610mm): telescopic dome shaft with vehicle loading lid or HGV loading (max. effective length 440mm) as well as the extension (max. effective length 305mm).

Attention: Use the vehicle cover under all circumstances.

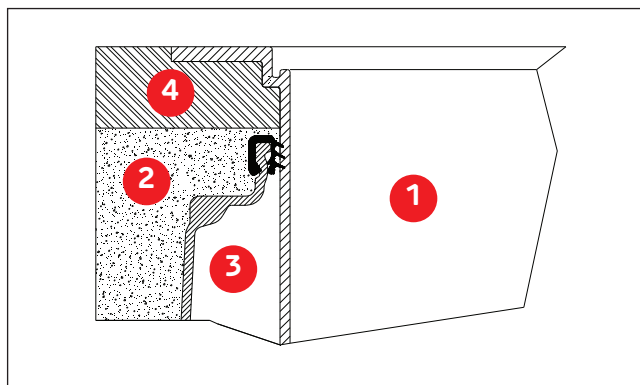

5.5 Telescopic dome shaft for HGV loading

When installing below surfaces driven on by HGVs, the telescopic dome shaft is lined **1** as described in 6.4. The concrete rings **6** (diameter 600mm) and a cast frame **5** with star-shaped load distribution are then installed to support the cast cover. The cast frame must have a contact area of approx. 1m². To extend the shaft, the telescopic dome shaft for HGV loading with class D cover, provided by the customer (max. useful length 440mm), and the extension (max. useful length 305mm) can be used.

Please note: Can only be driven over with HGV, if self-supporting, steel-reinforced concrete plate is installed!

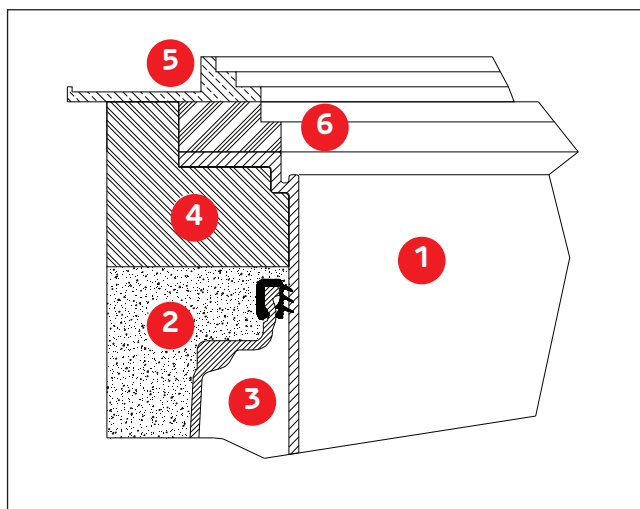

5.6 Assembling the extension

For larger coverage heights an extension is needed. To insert the extension into the tank dome, soft soap is needed. Into the highest groove of the extension the profile seal is inserted and greased generously. Afterwards push the telescopic dome shaft onto the extension and adjust it to the planned area surface. **max. earth-cover 1500mm**

- 1** Telescopic dome shaft (can be inclined by 5°)
- 2** Extension
- 3** Tank dome (can be rotated by 360°)

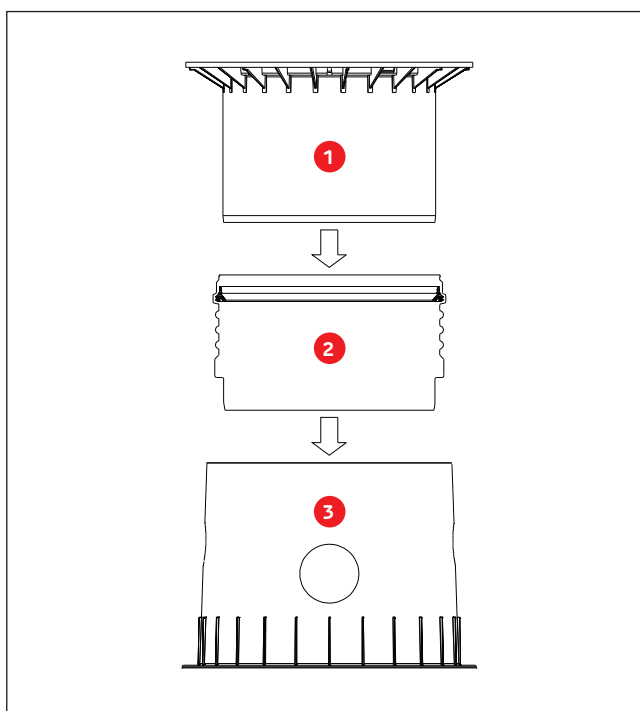

6. INSPECTION AND SERVICING

The entire system must be checked for leaks, cleanliness and stability at least every three months.

The entire system should be serviced at intervals of approx. 5 years. In this case, all parts of the system must be cleaned and their function checked. Servicing should be carried out as follows:

- Drain the tank completely
- Clean surfaces and internal parts with water
- Remove all dirt from the tank
- Check that all internal parts are firmly connected.

The points described in these instructions must be observed under all circumstances. All warranty rights are invalidated in the event of non-observance. Separate installation instructions are enclosed in the transportation packaging for all additional articles purchased from GRAF.

The components must be checked for any damage prior to installation under all circumstances.

Missing instructions can be downloaded on www.graf.info or can be requested from GRAF.



RAINWATER HARVESTING

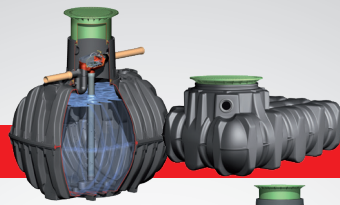

WASTEWATER MANAGEMENT

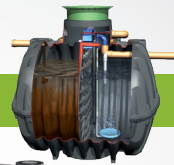

STORMWATER MANAGEMENT



WATER BUTTS & COMPOSTERS



MULTIPURPOSE CONTAINERS



Graf UK Ltd
Regen House
Beaumont Road
Banbury
Oxfordshire OX16 1RH

T: 01608 661500
F: 01295 211333
E: info@grafuk.co.uk
www.grafuk.co.uk

Graf UK Ltd (Scotland)
220 Blairtummock Road
Queenslie Industrial
Estate
Glasgow G33 4ED

T: 0141 465 1540
F: 01295 211333
E: info@grafuk.co.uk
www.grafuk.co.uk